



phyCORE[®]-AM64x

Arm[®] Cortex[®]-A53/-R5F/-M4F

Designed for industrial communication, controls and smart manufacturing applications.

The phyCORE-AM64x is a robust and reliable headless embedded solution for industrial communication applications. The 50 mm x 37 mm SOM has an extensive 280-pin interconnect that supports common communication protocols such as CAN, EtherCAT[®], UART, I2C, but also automation-specific interfaces such as ePWM, eCAP and eQEP. Due to the heterogeneous architecture of the TI AM64x processor, you can run the majority of your application using Linux and outsource critical components to the specialized real-time cores with low latency.

Highlights

- Single- or dual-core Arm[®] Cortex[®]-A53 (up to 1 GHz)
- Up to 4x Cortex[®]-R5F cores (up to 800 MHz) for real-time processing
- 1x isolated Cortex[®]-M4F MCU (up to 400 MHz) for general purposes, safety and critical tasks
- 4x PRU-ICSSG industrial Ethernet interfaces, usable with different communication protocol stacks (TSN, EtherCAT[®], PROFINET[®], EtherNet/IP[™] and others)
- No additional license costs for industrial protocol stacks
- ePWM, eCAP and eQEP supported
- DDR4 with inline ECC
- Simplification of the base board design due to +3.3 V / 2 A voltage output at the module

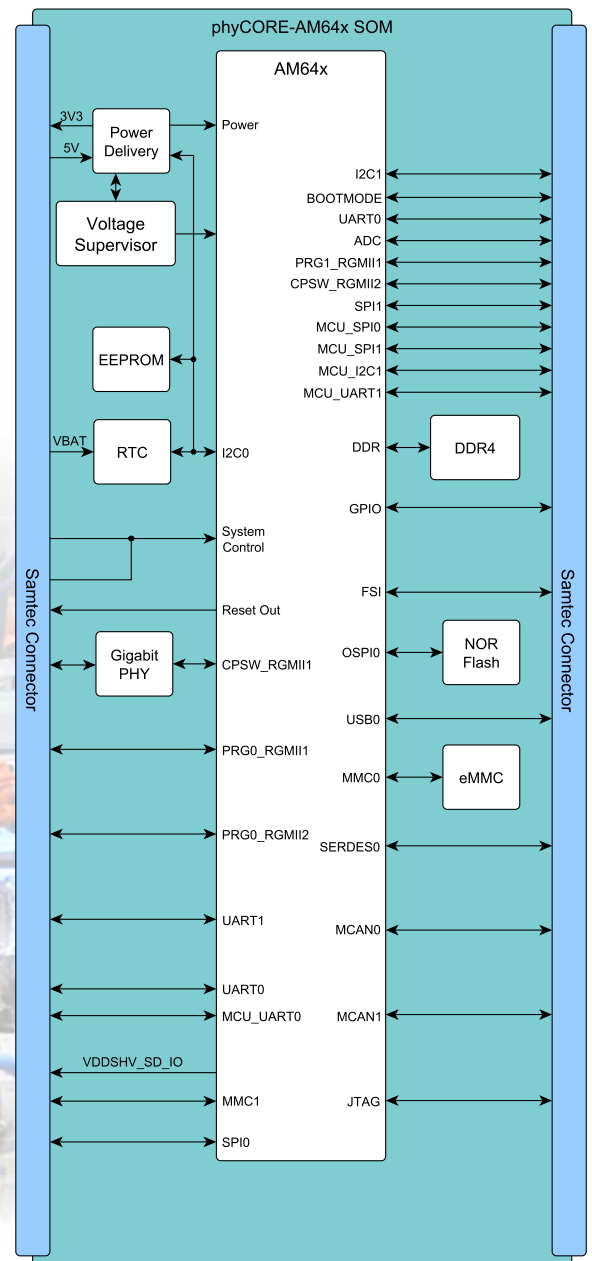

www.phytec.eu/en/phycore-am64x

Technical Data

Module Configuration

SOC	
Processor	TI AM6411, TI AM6412, TI AM6424, TI AM6441, TI AM6442
Core	up to 2x Arm® Cortex®-A53
Coprocessor	up to 4x Arm® Cortex®-R5F, Arm® Cortex®-M4F
Clock frequency	up to 1 GHz (A53), up to 800 MHz (R5F), up to 400 MHz (M4F)
L2 Cache	256 kB L2 with ECC
Internal RAM	2 MB SRAM with ECC
HW Security	3DES, AES, DRBG, MD5, PKA, SHA-1, SHA-2
EXT. MEMORY	
eMMC	4 GB up to 128 GB
DDR4	1 GB up to 2 GB maximal
NOR Flash	64 MB up to 256 MB (Octal SPI/Dual SPI Flash)
EEPROM	4 kB up to 32 kB
PHYSICAL PROPERTIES	
Dimensions	50 mm x 37 mm x 7.6 mm
Weight	tbd.
Operating temperature	-40 °C to +85 °C
Humidity	95 % rF non condensing
Operating voltage	5.0 V
Power consumption typ.	tbd.
Connector	2x 140 pin Samtec, 0.5 mm pitch
SOFTWARE	
Operating system	Linux
Real-time operating system	freeRTOS

Ordering Information

Module	PCM-072
Carrier board	PB-07225
Development Kit	KPB-07225

Carrier Board phyCORE-AM64x

Versatile development platform

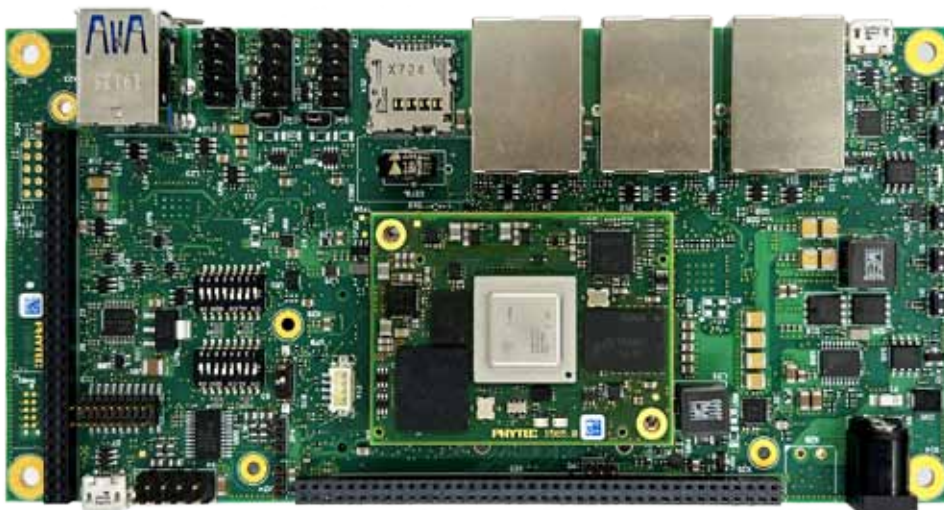

Module Interfaces

MAXIMUM INTERFACES*, **	
Ethernet	2x Gigabit (1x on-board PHY / 1x RGMII), 4x Gigabit Industrial (PRU-ICSSG)
USB	1x 2.0 Dual Role, 1x 3.1 Dual Role
UART	up to 9
CAN	2x CAN FD
PCI / PCIe	1x PCIe 2.0
I²C	up to 6
SPI	up to 7
MMC/SD/SDIO	1
PWM	up to 9
GPMC	yes
ADC	up to 8
Debugging	JTAG
Power-Out	+3.3 V / 2 A
RTC	on-board

* Due to multiplexing, not all interfaces may be fully available.

** Due to the exclusive use of individual interfaces on the module, the maximum number may differ from the processor specification.

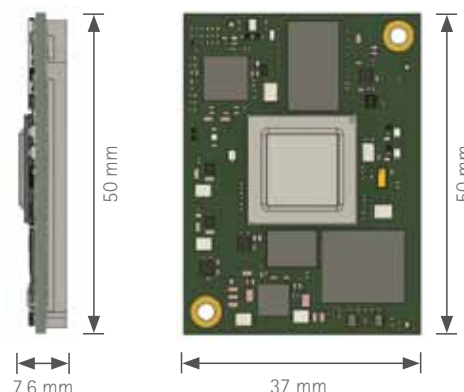

INTERFACES	
Ethernet	3x 10/100/1000BASE-T (TSN support)
USB	1x USB 2.0 OTG (Micro-AB) 2x USB 3.0 host (Type-A)
Serial	1x RS-232 or RS-485; 1x FSI, 2x CAN FD (4x pin header 2x5)
PCI / PCIe	1x PCIe 2.0 (Mini PCIe)
Debugging	JTAG (pin header), XDS110 (Micro-AB)
Various	I²C, SPI, ADC, GPIO (Expansion sockets)
MISCELLANEOUS	
MMC/SD/SDIO	microSD Card Slot
User Control	2x LED, 1x RGB LED, 5x button
Dimensions	160 mm x 78 mm
Supply Voltage	12 V to 24 V