

phyCORE[®] -i.MX 6

Hardware Manual

Document No.: **L-808e_2**
SOM Prod. No.: **PCM-058**
SOM PCB. No.: **1429.3**

Edition: August 2016

Copyrighted products are not explicitly indicated in this manual. The absence of the trademark (™, or ®) and copyright (©) symbols does not imply that a product is not protected. Additionally, registered patents and trademarks are similarly not expressly indicated in this manual.

The information in this document has been carefully checked and is considered to be entirely reliable. However, PHYTEC Messtechnik GmbH assumes no responsibility for any inaccuracies. PHYTEC Messtechnik GmbH neither gives any guarantee nor accepts any liability whatsoever for consequential damages resulting from the use of this manual or its associated product. PHYTEC Messtechnik GmbH reserves the right to alter the information contained herein without prior notification and accepts no responsibility for any damages that might result.

Additionally, PHYTEC Messtechnik GmbH offers no guarantee nor accepts any liability for damages arising from the improper usage or improper installation of the hardware or software. PHYTEC Messtechnik GmbH further reserves the right to alter the layout and/or design of the hardware without prior notification and accepts no liability for doing so.

© Copyright 2016 PHYTEC Messtechnik GmbH, D-55129 Mainz.

Rights - including those of translation, reprint, broadcast, photomechanical or similar reproduction and storage or processing in computer systems, in whole or in part - are reserved. No reproduction may occur without the express written consent from PHYTEC Messtechnik GmbH.

	EUROPE	NORTH AMERICA	FRANCE
Address:	PHYTEC Messtechnik GmbH Robert-Koch-Str. 39 D-55129 Mainz GERMANY	PHYTEC America LLC 203 Parfitt Way SW Bainbridge Island, WA 98110 USA	PHYTEC France 17, place Saint-Etienne F-72140 Sillé-le-Guillaume FRANCE
Ordering Information:	+49 6131 9221-32 sales@phytec.de	+1 800 278-9913 sales@phytec.com	+33 2 43 29 22 33 info@phytec.fr
Technical Support:	+49 6131 9221-31 support@phytec.de	+1 206 780-9047 support@phytec.com	support@phytec.fr
Fax:	+49 6131 9221-33	+1 206 780-9135	+33 2 43 29 22 34
Web Site:	http://www.phytec.de http://www.phytec.eu	http://www.phytec.com	http://www.phytec.fr

	INDIA	CHINA
Address:	PHYTEC Embedded Pvt. Ltd. #16/9C, 3rd Main, 3rd Floor, 8th Block, Opp. Police Station Koramangala, Bangalore-560095 INDIA	PHYTEC Information Technology (Shenzhen) Co. Ltd. Suite 2611, Floor 26, Anlian Plaza, 4018 Jin Tian Road Futian District, Shenzhen CHINA 518026
Ordering Information:	+91-80-4086 7046/48 sales@phytec.in	+86-755-3395-5875 sales@phytec.cn
Technical Support:	+91-80-4086 7047 support@phytec.in	support@phytec.cn
Fax:		+86-755-3395-5999
Web Site:	http://www.phytec.in	http://www.phytec.cn

List of Figures	iii
List of Tables	iv
Conventions, Abbreviations and Acronyms	v
Preface	viii
1 Introduction	1
1.1 Features of the phyCORE-i.MX 6	1
1.2 Block Diagram	3
1.3 phyCORE-i.MX 6 Component Placement	4
1.4 Minimum Requirements to operate the phyCORE-i.MX 6	6
2 Pin Description	7
3 Jumpers	18
4 Power	22
4.1 Primary System Power (VDD_3V3)	22
4.2 Power Management IC (PMIC) (U16)	22
4.2.1 Power Domains.....	23
4.3 Supply Voltage for external Logic	25
4.4 Backup Power (PMIC_VBAT/VDD_MX6_SNVS)	25
5 Reset	26
6 System Configuration and Booting	27
6.1 Boot Mode Selection	27
6.2 Boot Device Selection and Configuration	28
7 System Memory	30
7.1 DDR3-SDRAM (U4-U7)	30
7.2 NAND Flash Memory (U12)	31
7.3 eMMC Flash Memory (U14)	31
7.4 I ² C EEPROM (U11)	31
7.4.1 EEPROM Write Protection Control (J4)	32
7.5 SPI Flash Memory (U9))	32
8 SD / MM Card Interfaces	33
9 Serial Interfaces	34
9.1 Universal Asynchronous Interface	34
9.2 USB OTG Interface	35
9.3 USB Host Interface.....	35
9.4 Ethernet Interface	36
9.4.1 Ethernet PHY (U2).....	36
9.4.2 Software Reset of the Ethernet Controller	37
9.4.3 MAC Address	37
9.4.4 RMI Interface.....	38
9.5 SPI Interface.....	39
9.6 I ² C Interface	40
9.7 I ² S Audio Interface (SSI)	40
9.8 CAN Interface.....	41
9.9 SATA Interface	41
9.10 PCI Express Interface	42

10	General Purpose I/Os	43
11	User LED	44
12	Debug Interface	45
13	Display Interfaces	46
	13.1 Parallel Display Interface	46
	13.2 LVDS Display Interface	47
	13.3 Supplementary Signals.....	47
14	High-Definition Multimedia Interface (HDMI)	48
15	Camera Interfaces	49
	15.1 Parallel 0 Camera Interface (CSIO of IPU#1).....	51
	15.2 Parallel 1 Camera Interface (CSI1 of IPU#2).....	52
	15.3 MIPI/CSI-2 Camera Interface.....	53
	15.4 Utilizing the Camera Interfaces on a Carrier Board	54
16	Tamper Detection	55
17	Technical Specifications	56
	17.1 Product Temperature Grades	58
	17.2 Connectors on the phyCORE-i.MX 6:	59
18	Hints for Integrating and Handling the phyCORE-i.MX 6	60
	18.1 Integrating the phyCORE-i.MX 6	60
	18.2 Handling the phyCORE-i.MX 6	62
19	Revision History	63
	Index	65

List of Figures

Figure 1:	Block Diagram of the phyCORE-i.MX 6	3
Figure 2:	phyCORE-i.MX 6 Component Placement (top view)	4
Figure 3:	phyCORE-i.MX 6 Component Placement (bottom view)	5
Figure 4:	Pinout of the phyCORE-Connector (top view)	8
Figure 5:	Typical Jumper Pad Numbering Scheme	18
Figure 6:	Jumper Locations (top view)	19
Figure 7:	Jumper Locations (bottom view)	20
Figure 8:	Powering Scheme of the phyCORE- i.MX 6	24
Figure 9:	User LED Location (top view)	44
Figure 10:	Camera Connectivity of the i.MX 6 (Solo/DualLite)	49
Figure 11:	Camera Connectivity of the i.MX 6 (Dual Core/Quad Core)	49
Figure 12:	Camera Interfaces at the phyCORE-Connector (Parallel 0(CSI0 of IPU#1), Parallel 1(CSI1 of IPU#2), and MIPI/CSI-2)	50
Figure 13:	Use of Parallel 0 (CSI0 of IPU#1) and Parallel 1 (CSI1 of IPU#2) as phyCAM-P interface	54
Figure 14:	Use of Parallel 0 (CSI0 of IPU#1) and Parallel 1 (CSI1 of IPU#2) as phyCAM-S+ interface	54
Figure 15:	Physical Dimensions (top view)	56
Figure 16:	Footprint of the phyCORE-i.MX 6	61

List of Tables

Table 1:	Signal Types used in this Manual	vi
Table 2:	Abbreviations and Acronyms used in this Manual.....	vii
Table 3:	Pinout of the phyCORE-Connector X1, Row A	10
Table 4:	Pinout of the phyCORE-Connector X1, Row B	12
Table 5:	Pinout of the phyCORE-Connector X1, Row C	14
Table 6:	Pinout of the phyCORE-Connector X1, Row D	16
Table 7:	Jumper Settings	21
Table 8:	Boot Modes of the phyCORE-i.MX 6	27
Table 9:	Boot Configuration Pins at the phyCORE-Connector.....	29
Table 10:	EEPROM write protection states via J4	32
Table 11:	Location of the SD / MM Card Interface Signals.....	33
Table 12:	Location of the UART Signals	34
Table 13:	Location of the USB OTG Signals.....	35
Table 14:	Location of the USB Host Signals.....	35
Table 15:	Location of the Ethernet Signals	36
Table 16:	Location of the RMI Interface Signals.....	38
Table 17:	SPI Interface Signal Location.....	39
Table 18:	I ² C Interface Signal Location	40
Table 19:	I ² S Interface Signal Location	40
Table 20:	CAN Interface Signal Location.....	41
Table 21:	SATA Interface Signal Location	41
Table 22:	PCIe Interface Signal Location	42
Table 23:	Location of GPIO Pins	43
Table 24:	Debug Interface Signal Location at phyCORE-Connector X1.....	45
Table 25:	Parallel Display Interface Signal Location.....	46
Table 26:	LVDS Display Interface Signal Location	47
Table 27:	Supplementary Signals to support the Display Connectivity	47
Table 28:	HDMI Interface Signal Location.....	48
Table 29:	Camera Interface Parallel 0 (IPU1_CSI0) Signal Location.....	51
Table 30:	Camera Interface Parallel 1 (IPU2_CSI1) Signal Location.....	52
Table 31:	Camera Interface MIPI/CSI-2 Signal Location.....	53
Table 32:	Technical Specifications	57
Table 33:	Product Temperature Grades.....	58

Conventions, Abbreviations and Acronyms

This hardware manual describes the PCM-058 System on Module in the following referred to as phyCORE®-i.MX 6. The manual specifies the phyCORE®-i.MX 6's design and function. Precise specifications for the NXP® Semiconductor i.MX 6 microcontrollers can be found in the enclosed microcontroller Data Sheet/User's Manual.

Note: We refrain from providing detailed part specific information within this manual, which can be subject to continuous changes, due to part maintenance for our products. Please read the paragraph "**Product Change Management and information in this manual on parts populated on the SOM**" within the [Preface](#).

Note: The BSP delivered with the phyCORE®-i.MX 6 usually includes drivers and/or software for controlling all components such as interfaces, memory, etc. Therefore programming close to hardware at register level is not necessary in most cases. For this reason, this manual contains no detailed description of the controller's registers, or information relevant for software development. Please refer to the *i.MX 6 Reference Manual*, if such information is needed to connect customer designed applications.

Conventions

The conventions used in this manual are as follows:

- Signals that are preceded by an "n", "/", or "#" character (e.g.: nRD, /RD, or #RD), or that have a dash on top of the signal name (e.g.: $\overline{\text{RD}}$) are designated as active low signals. That is, their active state is when they are driven low, or are driving low.
- A "0" indicates a logic zero or low-level signal, while a "1" represents a logic one or high-level signal.
- The hex-numbers given for addresses of I²C devices always represent the 7 MSB of the address byte. The correct value of the LSB which depends on the desired command (read (1), or write (0)) must be added to get the complete address byte. E.g. given address in this manual 0x41 => complete address byte = 0x83 to read from the device and 0x82 to write to the device
- Tables which describe jumper settings show the default position in **bold, blue text**.
- Text in *blue italic* indicates a hyperlink within, or external to the document. Click these links to quickly jump to the applicable URL, part, chapter, table, or figure.
- References made to the phyCORE-Connector always refer to the high density Samtec connector on the undersides of the phyCORE-i.MX 6 System on Module.

Types of Signals

Different types of signals are brought out at the phyCORE-Connector. The following table lists the abbreviations used to specify the type of a signal.

Signal Type	Description	Abbr.
Power	Supply voltage input	PWR_I
Ref-Voltage	Reference voltage output	REF_0
Input	Digital input	I
Output	Digital output	O
IO	Bidirectional input/output	I/O
OC-Bidir PU	Open collector input/output with pull up	OC-BI
OC-Output	Open collector output without pull up, requires an external pull up	OC
5V Input PD	5 V tolerant input with pull down	5V_PD
LVDS Input	Differential line pairs 100 Ohm LVDS level input	LVDS_I
LVDS Output	Differential line pairs 100 Ohm LVDS level output	LVDS_O
TMDS Output	Differential line pairs 100 Ohm TMDS level output	TMDS_O
USB IO	Differential line pairs 90 Ohm USB level bidirectional input/output	USB_I/O
ETHERNET Input	Differential line pairs 100 Ohm Ethernet level input	ETH_I
ETHERNET Output	Differential line pairs 100 Ohm Ethernet level output	ETH_O
ETHERNET IO	Differential line pairs 100 Ohm Ethernet level bidirectional input/output	ETH_I/O
PCIe Input	Differential line pairs 100 Ohm PCIe level input	PCIe_I
PCIe Output	Differential line pairs 100 Ohm PCIe level output	PCIe_O
MIPI CSI-2 Input	Differential line pairs 100 Ohm MIPI CSI-2 level input	CSI-2_I

Table 1: Signal Types used in this Manual

Abbreviations and Acronyms

Many acronyms and abbreviations are used throughout this manual. Use the table below to navigate unfamiliar terms used in this document.

Abbreviation	Definition
BSP	Board Support Package (Software delivered with the Development Kit including an operating system (Windows, or Linux) preinstalled on the module and Development Tools).
CB	Carrier Board; used in reference to the phyCORE Development Kit Carrier Board.
DFF	D flip-flop.
EMB	External memory bus.
EMI	Electromagnetic Interference.
GPI	General purpose input.
GPIO	General purpose input and output.
GPO	General purpose output.
IRAM	Internal RAM; the internal static RAM on the NXP® Semiconductor i.MX 6 microcontroller.
J	Solder jumper; these types of jumpers require solder equipment to remove and place.
JP	Solderless jumper; these types of jumpers can be removed and placed by hand with no special tools.
PCB	Printed circuit board.
PDI	PHYTEC Display Interface; defined to connect PHYTEC display adapter boards, or custom adapters
PEB	PHYTEC Extension Board
PMIC	Power management IC
PoE	Power over Ethernet
POR	Power-on reset
RTC	Real-time clock.
SMT	Surface mount technology.
SOM	System on Module; used in reference to the PCM-058 /phyCORE® -i.MX 6 module
Sx	User button Sx (e.g. S1, S2, etc.) used in reference to the available user buttons, or DIP-Switches on the carrier board.
Sx_y	Switch y of DIP-Switch Sx; used in reference to the DIP-Switch on the carrier board.

Table 2: Abbreviations and Acronyms used in this Manual

Preface

As a member of PHYTEC's phyCORE® product family the phyCORE-i.MX 6 is one of a series of PHYTEC System on Modules (SOMs) that can be populated with different controllers and, hence, offers various functions and configurations. PHYTEC supports a variety of 8-/16- and 32-bit controllers in two ways:

- (1) as the basis for Rapid Development Kits which serve as a reference and evaluation platform
- (2) as insert-ready, fully functional phyCORE® OEM modules, which can be embedded directly into the user's peripheral hardware design.

Implementation of an OEM-able SOM subassembly as the "core" of your embedded design allows you to focus on hardware peripherals and firmware without expending resources to "re-invent" microcontroller circuitry. Furthermore, much of the value of the phyCORE® module lies in its layout and test.

Production-ready Board Support Packages (BSPs) and Design Services for our hardware will further reduce your development time and risk and allow you to focus on your product expertise. Take advantage of PHYTEC products to shorten time-to-market, reduce development costs, and avoid substantial design issues and risks. With this new innovative full system solution you will be able to bring your new ideas to market in the most timely and cost-efficient manner.

For more information go to:

<http://www.phytec.de/de/leistungen/entwicklungsunterstuetzung.html> or
<http://www.phytec.eu/europe/oem-integration/evaluation-start-up.html>

Ordering Information

The part numbering of the phyCORE has the following structure:

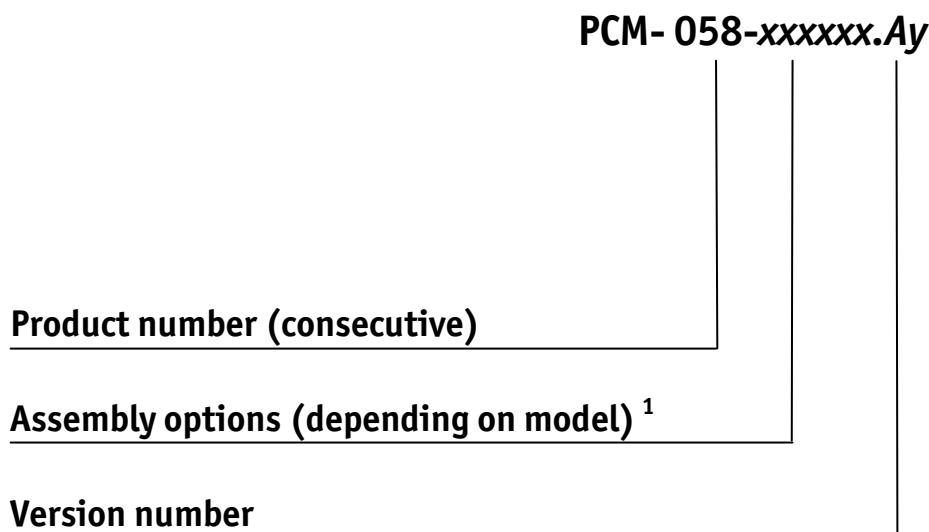

Product Specific Information and Technical Support

In order to receive product specific information on changes and updates in the best way also in the future, we recommend to register at

<http://www.phytec.de/de/support/registrierung.html> or
<http://www.phytec.eu/europe/support/registration.html>

For technical support and additional information concerning your product, please visit the support section of our web site which provides product specific information, such as errata sheets, application notes, FAQs, etc.

<http://www.phytec.de/support/knowledge-database/soms-system-on-modules/phycore/phycore-imx-6/>

or

<http://www.phytec.eu/europe/support/faq/faq-phyCORE-i.MX6.html>

¹: Assembly options include choice of Controller; RAM (Size/Type); Size of NAND Flash, etc.; Interfaces available; Vanishing; Temperature Range; and other features. Please contact our sales team to get more information on the ordering options available.

Declaration of Electro Magnetic Conformity of the PHYTEC phyCORE®-i.MX 6



PHYTEC System on Module (henceforth products) are designed for installation in electrical appliances or as dedicated Evaluation Boards (i.e.: for use as a test and prototype platform for hardware/software development) in laboratory environments.

Caution!

PHYTEC products lacking protective enclosures are subject to damage by ESD and, hence, may only be unpacked, handled or operated in environments in which sufficient precautionary measures have been taken in respect to ESD-dangers. It is also necessary that only appropriately trained personnel (such as electricians, technicians and engineers) handle and/or operate these products. Moreover, PHYTEC products should not be operated without protection circuitry if connections to the product's pin header rows are longer than 3 m.

PHYTEC products fulfill the norms of the European Union's Directive for Electro Magnetic Conformity only in accordance to the descriptions and rules of usage indicated in this hardware manual (particularly in respect to the pin header row connectors, power connector and serial interface to a host-PC).

Implementation of PHYTEC products into target devices, as well as user modifications and extensions of PHYTEC products, is subject to renewed establishment of conformity to, and certification of, Electro Magnetic Directives. Users should ensure conformance following any modifications to the products as well as implementation of the products into target systems.

Product Change Management and information in this manual on parts populated on the SOM / SBC

When buying a PHYTEC SOM / SBC, you will, in addition to our HW and SW offerings, receive a free obsolescence maintenance service for the HW we provide.

Our PCM (Product Change Management) Team of developers, is continuously processing, all incoming PCN's (Product Change Notifications) from vendors and distributors concerning parts which are being used in our products.

Possible impacts to the functionality of our products, due to changes of functionality or obsolescence of a certain part, are being evaluated in order to take the right measures in purchasing or within our HW/SW design.

Our general philosophy here is: **We never discontinue a product as long as there is demand for it.**

Therefore we have established a set of methods to fulfill our philosophy:

Avoiding strategies

- Avoid changes by evaluating long-livety of parts during design in phase.
- Ensure availability of equivalent second source parts.
- Stay in close contact with part vendors to be aware of roadmap strategies.

Change management in rare event of an obsolete and non replaceable part

- Ensure long term availability by stocking parts through last time buy management according to product forecasts.
- Offer long term frame contract to customers.

Change management in case of functional changes

- Avoid impacts on product functionality by choosing equivalent replacement parts.
- Avoid impacts on product functionality by compensating changes through HW redesign or backward compatible SW maintenance.
- Provide early change notifications concerning functional relevant changes of our products.

Therefore we refrain from providing detailed part specific information within this manual, which can be subject to continuous changes, due to part maintenance for our products.

In order to receive reliable, up to date and detailed information concerning parts used for our product, please contact our support team through the contact information given within this manual.

1 Introduction

The phyCORE-i.MX 6 belongs to PHYTEC's phyCORE System on Module family. The phyCORE SOMs represent the continuous development of PHYTEC System on Module technology. Like its mini-, micro- and nanoMODUL predecessors, the phyCORE boards integrate all core elements of a microcontroller system on a subminiature board and are designed in a manner that ensures their easy expansion and embedding in peripheral hardware developments.

As independent research indicates that approximately 70 % of all EMI (Electro Magnetic Interference) problems stem from insufficient supply voltage grounding of electronic components in high frequency environments, the phyCORE board design features an increased pin package. The increased pin package allows dedication of approximately 20 % of all connector pins on the phyCORE boards to Ground. This improves EMI and EMC characteristics and makes it easier to design complex applications meeting EMI and EMC guidelines using phyCORE boards even in high noise environments.

phyCORE boards achieve their small size through modern SMD technology and multi-layer design. In accordance with the complexity of the module, 0402-packaged SMD components and laser-drilled microvias are used on the boards, providing phyCORE users with access to this cutting edge miniaturization technology for integration into their own design.

The phyCORE-i.MX 6 is a subminiature (40 mm x 50 mm) insert-ready System on Module populated with the NXP® Semiconductor i.MX 6 microcontroller. Its universal design enables its insertion in a wide range of embedded applications. All controller signals and ports extend from the controller to high-density pitch (0.5 mm) connectors aligning two sides of the board, allowing it to be plugged like a "big chip" into a target application.

Precise specifications for the controller populating the board can be found in the applicable controller reference manual or datasheet. The descriptions in this manual are based on the NXP® Semiconductor i.MX 6. No description of compatible microcontroller derivative functions is included, as such functions are not relevant for the basic functioning of the phyCORE-i.MX 6.

1.1 Features of the phyCORE-i.MX 6

The phyCORE-i.MX 6 offers the following features:

- Insert-ready, sub-miniature (40 mm x 50 mm) System on Module (SOM) subassembly in low EMI design, achieved through advanced SMD technology
- Populated with the NXP® Semiconductor i.MX 6 microcontroller (BGA624 packaging)
- 1.0 GHz core clock frequency (optional 1.2 GHz)
- Boot from different memory devices (NAND Flash (standard))

- Controller signals and ports extend to two high-density (0.5 mm) Samtec connectors aligning two sides of the board, enabling the phyCORE-i.MX 6 to be plugged like a "big chip" into target application
- Single supply voltage of +3.3 V with on-board power management
- All controller required supplies are generated on board
- Improved interference safety achieved through multi-layer PCB technology and dedicated ground pins
- 512 MB (up to 2 GB²) DDR3 SDRAM
- 256 MB (up to 16 GB²) on-board NAND Flash
- Alternatively 2 GB (up to 32 GB²) on-board eMMC
- 16 MB² on-board serial Flash (bootable)
- 4 kB² I²C EEPROM
- Two serial interfaces (TTL). One with 4 lines allowing simple hardware handshake
- High-Speed USB OTG interface
- High-Speed USB HOST interface
- 10/100/1000 Mbit Ethernet interface. Either with Ethernet transceiver on the phyCORE-i.MX 6 allowing for direct connection to an existing Ethernet network, or without on-board transceiver and provision of the RMI signals at TTL-level at the phyCORE-Connector instead³
- I²C interface
- Two SPI interfaces
- PCIe interface
- I²S interface
- SPDIF interface
- PWM output
- CAN interface
- Two 4 channel LVDS (24 bit) LCD-interfaces
- Parallel LCD-interface with up to 24-bit
- HDMI interface
- Up to two parallel camera interfaces
- MIPI CSI camera interface
- Two SD/MMC card interfaces (1 x 8 bit, 1 x 4 bit)
- SATA interface
- JTAG interface
- One user programmable LED
- Several dedicated GPIOs⁴
- Power Management IC (PMIC)
- Available for different temperature grades ([section 17.1](#))

²: The maximum memory size listed is as of the printing of this manual. Please contact PHYTEC for more information about additional, or new module configurations available.

³: Please refer to the order options described in the Preface, or contact PHYTEC for more information about additional module configurations.

⁴: Almost every controller port which connects directly to the phyCORE-Connector may be used as GPIO by using the i.MX 6's pin muxing options.

1.2 Block Diagram

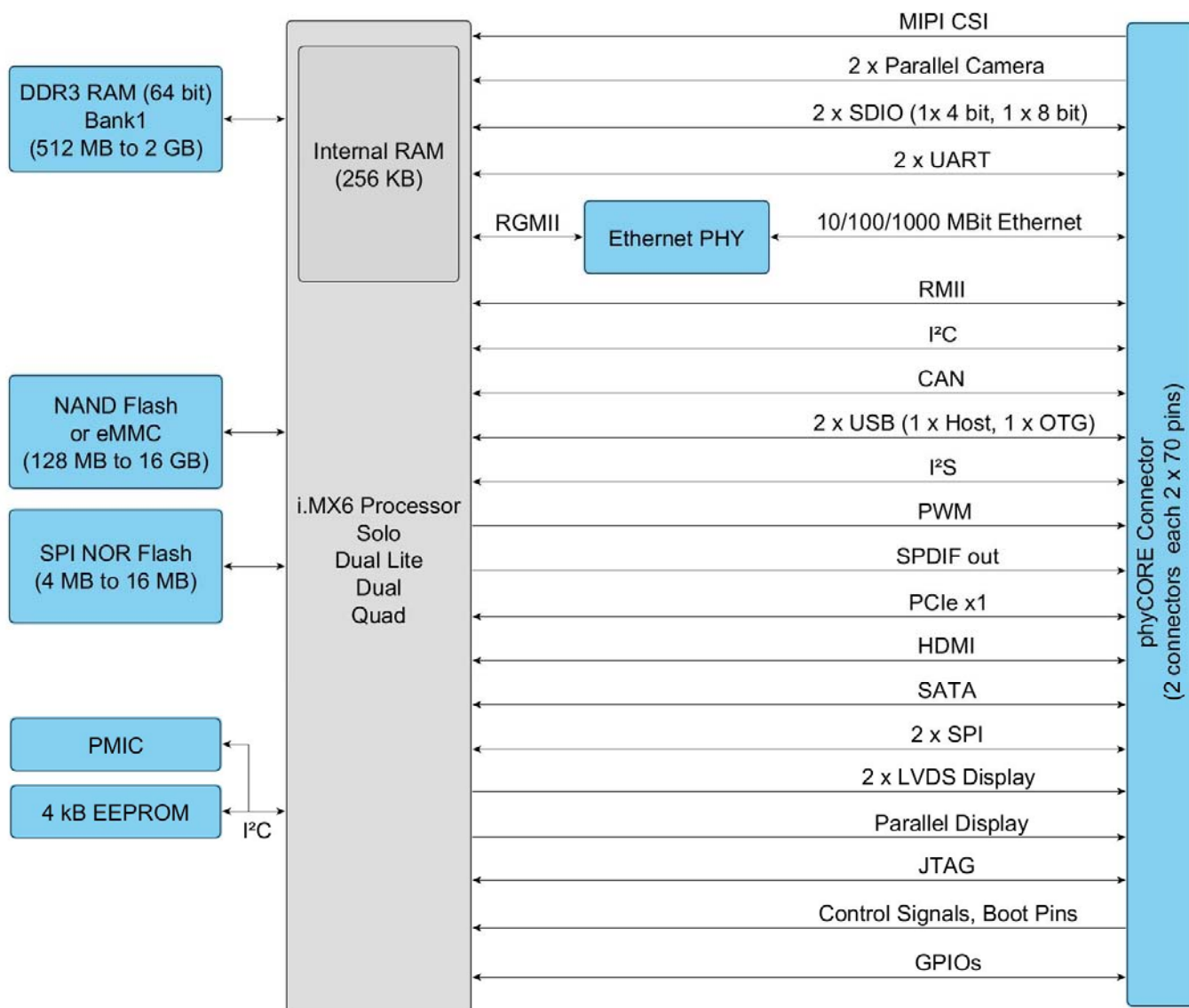

Figure 1: Block Diagram of the phyCORE-i.MX 6⁵

⁵: The specified direction indicated refers to the standard phyCORE use of the pin.

1.3 phyCORE-i.MX 6 Component Placement

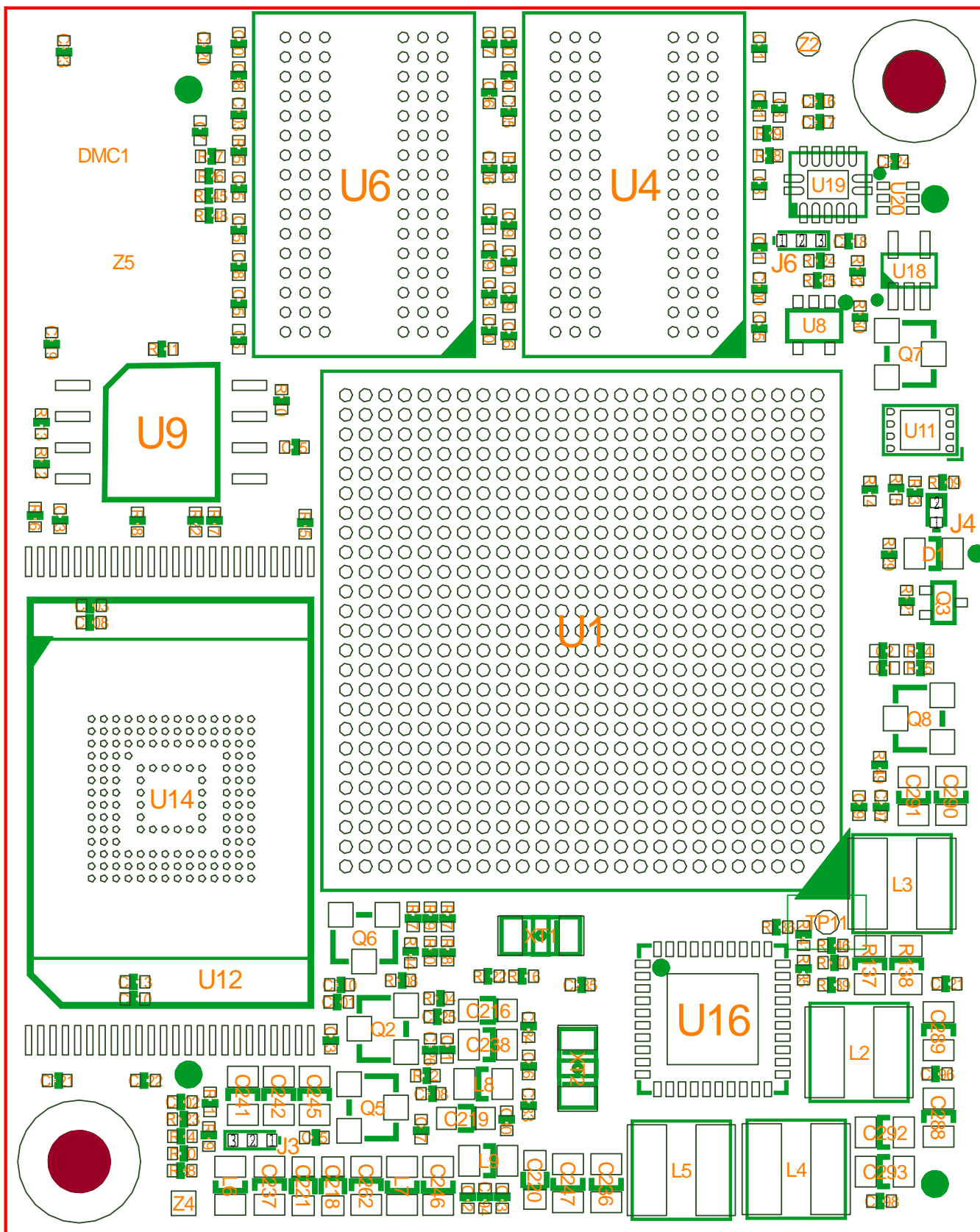

Figure 2: phyCORE-i.MX 6 Component Placement (top view)

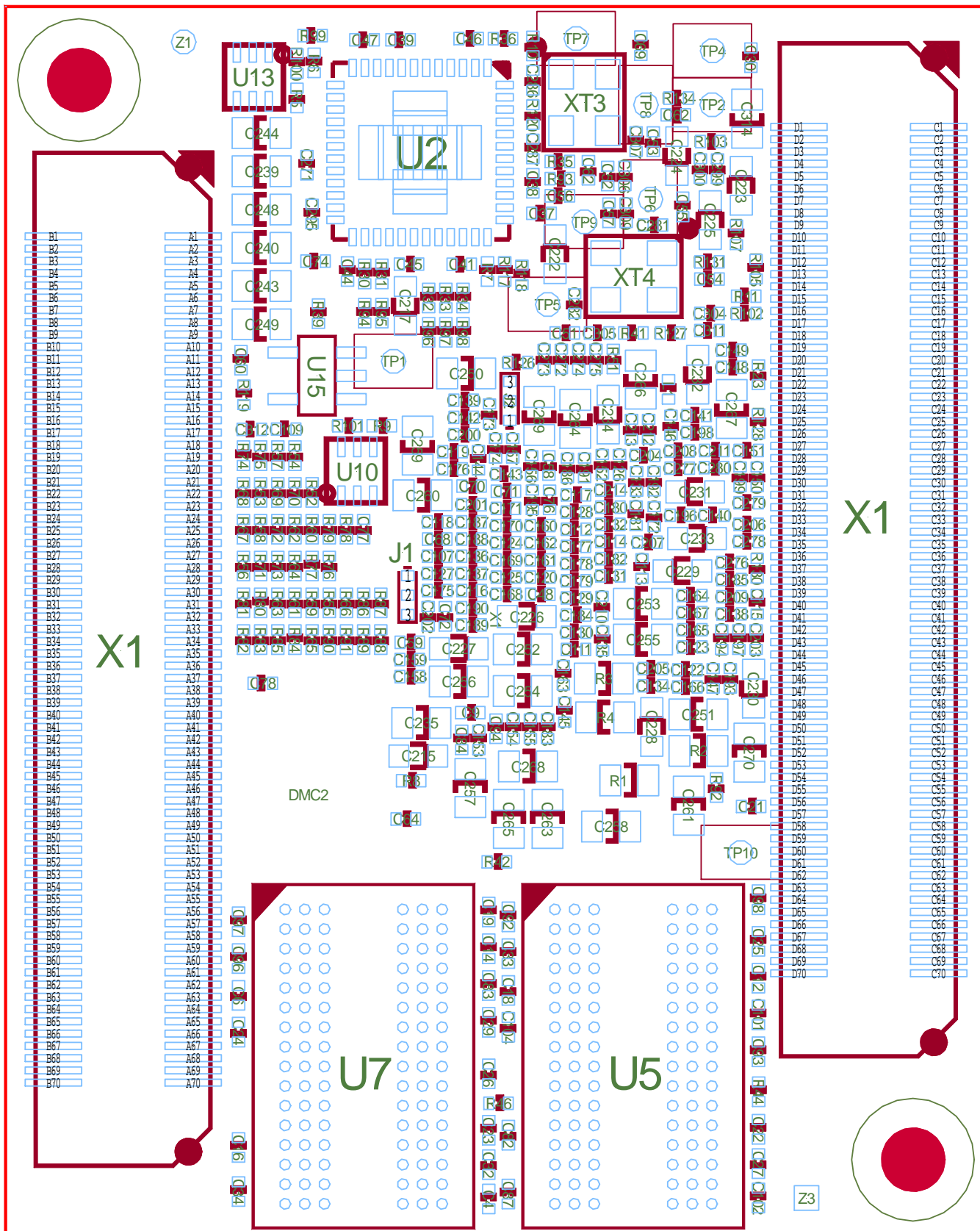

Figure 3: phyCORE-i.MX 6 Component Placement (bottom view)

1.4 Minimum Requirements to operate the phyCORE-i.MX 6

Basic operation of the phyCORE-i.MX 6 only requires supply of a +3.3 V input voltage with typical 2.5 A load and the corresponding GND connection.

These supply pins are located at the phyCORE-Connector X1:

VDD_3V3: X1 A1, A2, A3, A4, B1, B2, B3, B4

Connect all +3.3 V VCC input pins to your power supply and at least the matching number of GND pins.

Corresponding GND: X1 A6, A11, A16, A21, B6, B12, B17, B22

Please refer to [section 2](#) for information on additional GND Pins located at the phyCORE-Connector X1.

Caution!

We recommend connecting all available +3.3 V input pins to the power supply system on a custom carrier board housing the phyCORE-i.MX 6 and at least the matching number of GND pins neighboring the +3.3 V pins.

In addition, proper implementation of the phyCORE-i.MX 6 module into a target application also requires connecting all GND pins.

Please refer to [section 4](#) for more information.

2 Pin Description

Please note that all module connections are not to exceed their expressed maximum voltage or current. Maximum signal input values are indicated in the corresponding controller manuals/data sheets. As damage from improper connections varies according to use and application, it is the user's responsibility to take appropriate safety measures to ensure that the module connections are protected from overloading through connected peripherals.

As [Figure 4](#) indicates, all controller signals selected extend to surface mount technology (SMT) connectors (0.5 mm) lining two sides of the module (referred to as phyCORE-Connector). This allows the phyCORE-i.MX 6 to be plugged into any target application like a "big chip".

The numbering scheme for the phyCORE-Connector is based on a two dimensional matrix in which column positions are identified by a letter and row position by a number. The pin numbering values increase moving down on the board ([Figure 4](#)).

The numbered matrix can be aligned with the phyCORE-i.MX 6 (viewed from above; phyCORE-Connector pointing down) or with the socket of the corresponding phyCORE Carrier Board/user target circuitry. The upper left-hand corner of the numbered matrix (pin X1C1) is thus covered with the corner of the phyCORE-i.MX 6. The numbering scheme is always in relation to the PCB as viewed from above, even if all connector contacts extend to the bottom of the module.

The numbering scheme is thus consistent for both the module's phyCORE-Connector as well as the mating connector on the phyCORE Carrier Board or target hardware, thereby considerably reducing the risk of pin identification errors.

Since the pins are exactly defined according to the numbered matrix previously described, the phyCORE-Connector is usually assigned a single designator for its position (X1 for example). In this manner the phyCORE-Connector comprises a single, logical unit regardless of the fact that it could consist of more than one physical socketed connector.

The following figure illustrates the numbered matrix system. It shows a phyCORE-i.MX 6 with both SMT phyCORE-Connectors on its underside (defined as dotted lines) mounted on a carrier board. In order to facilitate understanding of the pin assignment scheme, the diagram presents a cross-view of the phyCORE-i.MX 6 module showing the phyCORE-Connector mounted on the underside of the module's PCB.

[Table 3](#) to [Table 6](#) provide an overview of the pinout of the phyCORE-Connector X1 with signal names and descriptions specific to the phyCORE-i.MX 6. It also provides the appropriate voltage domain, signal type (ST) and a functional grouping of the signals. The

signal type includes also information about the signal direction⁶. A description of the signal types can be found in [Table 1](#).

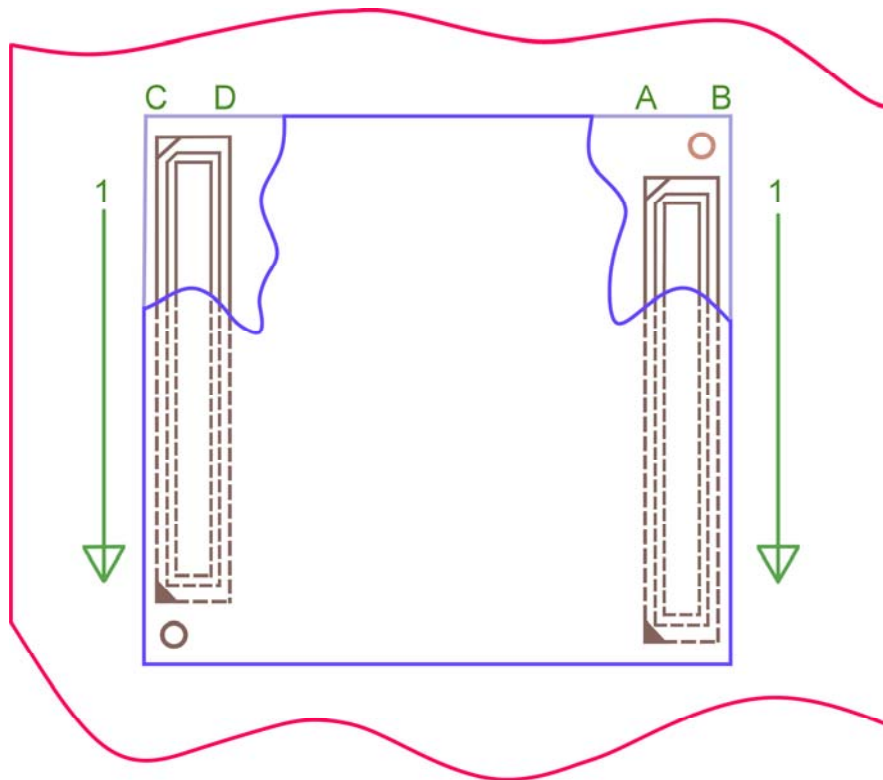

Figure 4: Pinout of the phyCORE-Connector (top view)

Caution!

- The NXP[®] Semiconductor i.MX 6 is a multi-voltage operated microcontroller and as such special attention should be paid to the interface voltage levels to avoid unintentional damage to the microcontroller and other on-board components. Please refer to the *NXP Semiconductor i.MX 6 Reference Manual* for details on the functions and features of controller signals and port pins.
- As some of the signals which are brought out on the phyCORE-Connector are used to configure the boot mode for specific boot options, please make sure that these signals are not driven by any device on the baseboard during reset. The signals which may affect the boot configuration are shown in [Table 9](#).
- It is mandatory to avoid voltages at the IO pins of the phyCORE-i.MX 6 which are sourced from the supply voltage of peripheral devices attached to the SOM during power-up, or power-down. These voltages can cause a current flow into the controller especially if peripheral devices attached to the interfaces of the i.MX 6 are supposed to be powered while the phyCORE-i.MX 6 is in suspend mode, or turned off. To avoid this bus switches either supplied by VDD_3V3_LOGIC on the phyCORE side, or having their output enable to the SOM controlled by the X_3V3_GOOD signal ([section 4.3](#)) must be used.

⁶: The specified direction indicated refers to the standard phyCORE use of the pin.

Note:

- Most of the controller pins have multiple multiplexed functions. As most of these pins are connected directly to the phyCORE-Connector the alternative functions are available by using the i.MX 6's pin muxing options. Signal names and descriptions in [Table 3](#) to [Table 6](#) however, are in regard to the specification of the phyCORE-i.MX 6 and the functions defined therein. Please refer to the *i.MX 6 Reference Manual*, or the schematic to get to know about alternative functions. In order to utilize a specific pin's alternative function the corresponding registers must be configured within the appropriate driver of the BSP.
- The following tables describe the full set of signals available at the phyCORE-Connector according to the phyCORE-i.MX 6 specification. However, the availability of some interfaces is order-specific (e.g. Camera_0). Thus, some signals might not be available on your module.
- If the phyCORE-i.MX 6 is delivered with a carrier board (e.g. the phyBOARD-Mira) the pin muxing might be changed within the appropriate BSP in order to support all features of the carrier board. If so, information on the differences from the pinout given in the following tables can be found in the carrier board's documentation.

Pin #	Signal	ST	Voltage domain	Description
A1	VDD_3V3	PWR_I	3.3 V	3.3 V Primary Voltage Supply Input
A2	VDD_3V3	PWR_I	3.3 V	3.3 V Primary Voltage Supply Input
A3	VDD_3V3	PWR_I	3.3 V	3.3 V Primary Voltage Supply Input
A4	VDD_3V3	PWR_I	3.3 V	3.3 V Primary Voltage Supply Input
A5	VDD_BAT	PWR_I	3.3 V	Backup Voltage Supply Input ⁷
A6	GND	-	-	Ground 0 V
A7	X_SD3_CMD	0	VDD_3V3_LOGIC	uSDHC3 command
A8	X_SD3_DATA0	I/O	VDD_3V3_LOGIC	uSDHC3 data 0
A9	X_SD3_DATA2	I/O	VDD_3V3_LOGIC	uSDHC3 data 2
A10	X_SD3_DATA5	I/O	VDD_3V3_LOGIC	uSDHC3 data 5
A11	GND	-	-	Ground 0 V
A12	X_SD3_DATA7	I/O	VDD_3V3_LOGIC	uSDHC3 data 7
A13	X_SD3_RESET	0	VDD_3V3_LOGIC	uSDHC3 reset
A14	X_SD1_DATA0	I/O	VDD_3V3_LOGIC	uSDHC1 data 0
A15	X_SD1_DATA2	I/O	VDD_3V3_LOGIC	uSDHC1 data 2
A16	GND	-	-	Ground 0 V
A17	X_UART2_RX_DATA	I	VDD_3V3_LOGIC	UART2 serial data receive
A18	X_UART3_RX_DATA	I	VDD_3V3_LOGIC	UART3 serial data receive
A19	X_UART3_CTS_B	0	VDD_3V3_LOGIC	UART3 clear to send output
A20	X_UART3_RTS_B	I	VDD_3V3_LOGIC	UART3 request to send input ⁸
A21	GND	-	-	Ground 0 V
A22	X_ECSP11_SCLK	I/O	VDD_3V3_LOGIC	eCSPI1 clock
A23	X_ECSP11_MOSI	I/O	VDD_3V3_LOGIC	eCSPI1 master output/slave input
A24	X_ECSP11_SS0	I/O	VDD_3V3_LOGIC	eCSPI1 chip select 0 ⁸
A25	X_EIM_DA13	I/O	VDD_3V3_LOGIC	EIM address/data 13 ^{9;10}
A26	GND	-	-	Ground 0 V
A27	X_CSI1_DATA12	I	VDD_3V3_LOGIC	IPU2_CSI1 data 12 ⁸
A28	X_CSI1_DATA11	I	VDD_3V3_LOGIC	IPU2_CSI1 data 11 ⁸
A29	X_CSI1_DATA10	I	VDD_3V3_LOGIC	IPU2_CSI1 data 10
A30	X_CSI1_DATA09	I	VDD_3V3_LOGIC	IPU2_CSI1 data 9 ⁸
A31	GND	-	-	Ground 0 V
A32	X_CSI1_DATA08	I	VDD_3V3_LOGIC	IPU2_CSI1 data 8 ⁸
A33	X_CSI1_DATA03	I	VDD_3V3_LOGIC	IPU2_CSI1 data 3 ⁸
A34	X_CSI1_DATA02	I	VDD_3V3_LOGIC	IPU2_CSI1 data 2 ⁸
A35	X_CSI1_DATA_EN	0	VDD_3V3_LOGIC	IPU2_CSI1 data enable ⁸
A36	GND	-	-	Ground 0 V

Table 3: Pinout of the phyCORE-Connector X1, Row A

⁷: connects to PMIC_VBBAT or VDD_MX6_SNVS via J3 (Table 7)

Pin #	Signal	ST	Voltage Domain	Description
A37	X_CSI1_DATA01	I	VDD_3V3_LOGIC	IPU2_CSI1 data 1 ⁸
A38	X_CSI1_DATA00	I	VDD_3V3_LOGIC	IPU2_CSI1 data 0 ⁸
A39	X_CSI1_VSYNC	I	VDD_3V3_LOGIC	IPU2_CSI1 vertical sync ⁸
A40	X_CSI1_HSYNC	I	VDD_3V3_LOGIC	IPU2_CSI1 horizontal sync ⁸
A41	GND	-	-	Ground 0 V
A42	X_EIM_BCLK	O	VDD_3V3_LOGIC	EIM burst block ¹⁰
A43	X_ECSPi2_MISO	I/O	VDD_3V3_LOGIC	eCSPI2 master input/slave output
A44	X_ECSPi2_SS1	I/O	VDD_3V3_LOGIC	eCSPI2 chip select 1 ⁸
A45	X_ECSPi2_SS0	I/O	VDD_3V3_LOGIC	eCSPI2 chip select 0 ⁸
A46	GND	-	-	Ground 0 V
A47	X_LCD_DATA22	O	VDD_3V3_LOGIC	DISPO data 22
A48	X_LCD_DATA21	O	VDD_3V3_LOGIC	DISPO data 21
A49	X_LCD_DATA19	O	VDD_3V3_LOGIC	DISPO data 19
A50	X_LCD_DATA16	O	VDD_3V3_LOGIC	DISPO data 16
A51	GND	-	-	Ground 0 V
A52	X_LCD_DATA14	O	VDD_3V3_LOGIC	DISPO data 14
A53	X_LCD_DATA13	O	VDD_3V3_LOGIC	DISPO data 13
A54	X_LCD_DATA11	O	VDD_3V3_LOGIC	DISPO data 11
A55	X_LCD_DATA08	O	VDD_3V3_LOGIC	DISPO data 8
A56	GND	-	-	Ground 0 V
A57	X_LCD_DATA06	O	VDD_3V3_LOGIC	DISPO data 6
A58	X_LCD_DATA05	O	VDD_3V3_LOGIC	DISPO data 5
A59	X_LCD_DATA03	O	VDD_3V3_LOGIC	DISPO data 3
A60	X_LCD_DATA00	O	VDD_3V3_LOGIC	DISPO data 0
A61	GND	-	-	Ground 0 V
A62	X_LCD_ENABLE	O	VDD_3V3_LOGIC	DISPO enable
A63	X_LCD_HSYNC	O	VDD_3V3_LOGIC	DISPO horizontal sync
A64	X_LCD_RESET	O	VDD_3V3_LOGIC	DISPO reset
A65	X_ENET_REFCLK	I	VDD_3V3_LOGIC	ENET RMII reference clock
A66	GND	-	-	Ground 0 V
A67	X_ENET_TXER	O	VDD_3V3_LOGIC	ENET transmit error
A68	X_ENET_RXD0	I	VDD_ENET_IO	ENET RMII receive data 0
A69	X_ENET_RXD1	I	VDD_ENET_IO	ENET RMII receive data 1
A70	X_ENET_RX_ER	I	VDD_ENET_IO	ENET RMII receive error

Table 3: Pinout of the phyCORE-Connector X1, Row A (continued)

Pin #	Signal	ST	Voltage Domain	Description
B1	VDD_3V3	PWR_I	3.3 V	3.3 V Primary Voltage Supply Input
B2	VDD_3V3	PWR_I	3.3 V	3.3 V Primary Voltage Supply Input
B3	VDD_3V3	PWR_I	3.3 V	3.3 V Primary Voltage Supply Input
B4	VDD_3V3	PWR_I	3.3 V	3.3 V Primary Voltage Supply Input
B5	VDD_3V3_LOGIC	REF_0	VDD_3V3_LOGIC	Logic reference voltage output
B6	GND	-	-	Ground 0 V
B7	X_SD3_CLK	0	VDD_3V3_LOGIC	uSDHC3 clock
B8	X_SD3_DATA1	I/O	VDD_3V3_LOGIC	uSDHC3 data 1
B9	X_SD3_DATA3	I/O	VDD_3V3_LOGIC	uSDHC3 data 3
B10	X_SD3_DATA4	I/O	VDD_3V3_LOGIC	uSDHC3 data 4
B11	X_SD3_DATA6	I/O	VDD_3V3_LOGIC	uSDHC3 data 6
B12	GND	-	-	Ground 0 V
B13	X_SD1_CLK	0	VDD_3V3_LOGIC	uSDHC1 clock
B14	X_SD1_CMD	0	VDD_3V3_LOGIC	uSDHC1 command
B15	X_SD1_DATA1	I/O	VDD_3V3_LOGIC	uSDHC1 data 1
B16	X_SD1_DATA3	I/O	VDD_3V3_LOGIC	uSDHC1 data 3
B17	GND	-	-	Ground 0 V
B18	X_UART3_TX_DATA	0	VDD_3V3_LOGIC	UART3 serial transmit signal
B19	X_ENET_MDIO	I/O	VDD_ENET_IO	ENET management data I/O
B20	X_ENET_MDC	0	VDD_ENET_IO	ENET management data clock
B21	X_UART2_TX_DATA	0	VDD_3V3_LOGIC	UART2 serial transmit signal
B22	GND	-	-	Ground 0 V
B23	X_I2C1_SCL	OC_BI	VDD_3V3_LOGIC	I2C1 clock
B24	X_I2C1_SDA	OC_BI	VDD_3V3_LOGIC	I2C1 data
B25	X_ECSP11_MISO	I/O	VDD_3V3_LOGIC	eCSPI1 master input/slave output
B26	X_EIM_DA14	I/O	VDD_3V3_LOGIC	EIM address/data 14 ^{9;10}
B27	X_EIM_DA15	I/O	VDD_3V3_LOGIC	EIM address/data 15 ^{9;10}
B28	GND	-	-	Ground 0 V
B29	X_CSI1_DATA19	I	VDD_3V3_LOGIC	IPU2_CSI1 data 19 ⁸
B30	X_CSI1_DATA18	I	VDD_3V3_LOGIC	IPU2_CSI1 data 18 ⁸
B31	X_CSI1_DATA17	I	VDD_3V3_LOGIC	IPU2_CSI1 data 17 ⁸
B32	X_CSI1_DATA16	I	VDD_3V3_LOGIC	IPU2_CSI1 data 16 ⁸
B33	GND	-	-	Ground 0 V
B34	X_CSI1_DATA15	I	VDD_3V3_LOGIC	IPU2_CSI1 data 15 ⁸
B35	X_CSI1_DATA14	I	VDD_3V3_LOGIC	IPU2_CSI1 data 14 ⁸
B36	X_CSI1_PIXCLK	0	VDD_3V3_LOGIC	IPU2_CSI1 pixel clock ⁸

Table 4: Pinout of the phyCORE-Connector X1, Row B

Pin #	Signal	ST	Voltage Domain	Description
B37	X_CSI1_DATA13	I	VDD_3V3_LOGIC	IPU2_CSI1 data 13 ⁸
B38	GND	-	-	Ground 0 V
B39	X_CSI1_DATA07	I	VDD_3V3_LOGIC	IPU2_CSI1 data 7 ⁸
B40	X_CSI1_DATA06	I	VDD_3V3_LOGIC	IPU2_CSI1 data 6 ⁸
B41	X_CSI1_DATA05	I	VDD_3V3_LOGIC	IPU2_CSI1 data 5 ⁸
B42	X_CSI1_DATA04	I	VDD_3V3_LOGIC	IPU2_CSI1 data 4 ⁸
B43	GND	-	-	Ground 0 V
B44	X_EIM_EB1	O	VDD_3V3_LOGIC	EIM enable byte 1 ^{9;10}
B45	X_ECSPi2_SCLK	I/O	VDD_3V3_LOGIC	eCSPI2 clock
B46	X_ECSPi2_RDY	I	VDD_3V3_LOGIC	eCSPI2 data ready
B47	X_ECSPi2_MOSI	I/O	VDD_3V3_LOGIC	eCSPI2 master output/slave input
B48	GND	-	-	Ground 0 V
B49	X_LCD_DATA23	O	VDD_3V3_LOGIC	DISP0 data 23
B50	X_LCD_DATA20	O	VDD_3V3_LOGIC	DISP0 data 20
B51	X_LCD_DATA18	O	VDD_3V3_LOGIC	DISP0 data 18
B52	X_LCD_DATA17	O	VDD_3V3_LOGIC	DISP0 data 17
B53	GND	-	-	Ground 0 V
B54	X_LCD_DATA15	O	VDD_3V3_LOGIC	DISP0 data 15
B55	X_LCD_DATA12	O	VDD_3V3_LOGIC	DISP0 data 12
B56	X_LCD_DATA10	O	VDD_3V3_LOGIC	DISP0 data 10
B57	X_LCD_DATA09	O	VDD_3V3_LOGIC	DISP0 data 9
B58	GND	-	-	Ground 0 V
B59	X_LCD_DATA07	O	VDD_3V3_LOGIC	DISP0 data 7
B60	X_LCD_DATA04	O	VDD_3V3_LOGIC	DISP0 data 4
B61	X_LCD_DATA02	O	VDD_3V3_LOGIC	DISP0 data 2
B62	X_LCD_DATA01	O	VDD_3V3_LOGIC	DISP0 data 1
B63	GND	-	-	Ground 0 V
B64	X_LCD_CLK	O	VDD_3V3_LOGIC	DISP0 clock
B65	X_LCD_VSYNC	O	VDD_3V3_LOGIC	DISP0 vertical sync
B66	X_ENET_CRSDV	I	VDD_ENET_IO	ENET RMII carrier sense/data valid
B67	X_ENET_TXEN	O	VDD_ENET_IO	ENET RMII TX enable
B68	GND	-	-	Ground 0 V
B69	X_ENET_TXD0	O	VDD_ENET_IO	ENET RMII transmit data 0
B70	X_ENET_TXD1	O	VDD_ENET_IO	ENET RMII transmit data 1

Table 4: Pinout of the phyCORE-Connector X1, Row B (continued)

⁸: Special care must be taken not to override the device configuration when using this pin as input ([section 6.2](#)).

⁹: Special care must be taken not to override the device configuration when using this pin as input ([section 6.2](#), [section 10](#)).

Pin #	Signal	ST	Voltage Domain	Description
C1	X_BOOT_MODE0	I	VDD_3V3_LOGIC	Boot mode input 0
C2	X_ETH0_A+/TX0+	ETH_0	VDD_3V3_LOGIC	ETH0 data A+/transmit+
C3	X_ETH0_A-/TX0-	ETH_0	VDD_3V3_LOGIC	ETH0 data A-/transmit-
C4	GND	-	-	Ground 0 V
C5	X_ETH0_C+	ETH_I/O	VDD_3V3_LOGIC	ETH0 data C+ (only GbE)
C6	X_ETH0_C-	ETH_I/O	VDD_3V3_LOGIC	ETH0 data C- (only GbE)
C7	X_ETH0_LED0	OC	VDD_3V3_LOGIC	ETH0 link LED output
C8	X_SATA_TXP	LVDS_0	i.MX6 internal	SATA PHY transmit lane+
C9	X_SATA_TXN	LVDS_0	i.MX6 internal	SATA PHY transmit lane-
C10	GND	-	-	Ground 0 V
C11	X_PCIE0_CLK+	PCIE_0	i.MX 6 internal	PCIe clock lane+
C12	X_PCIE0_CLK-	PCIE_0	i.MX 6 internal	PCIe clock lane-
C13	X_PCIE_RXP	PCIE_I	i.MX 6 internal	PCIe receive lane+
C14	X_PCIE_RXN	PCIE_I	i.MX 6 internal	PCIe receive lane-
C15	GND	-	-	Ground 0 V
C16	X_SPDIF_OUT	0	VDD_3V3_LOGIC	SPDIF output ¹⁰
C17	X_PWM1_OUT	0	VDD_3V3_LOGIC	PWM1 output ¹⁰
C18	X_USB_OTG_ID	I	VDD_3V3_LOGIC	USB OTG ID Pin
C19	X_USB_OTG_VBUS	PWR_I	5 V	USB OTG VBUS input
C20	X_USB_OTG_PWR	0	VDD_3V3_LOGIC	USB OTG power enable
C21	GND	-	-	Ground 0 V
C22	X_CCM_CLK02	0	VDD_3V3_LOGIC	CCM clock output 2
C23	X_USB_H1_DP	USB_I/O	i.MX 6 internal	USB Host1 data+
C24	X_USB_H1_DN	USB_I/O	i.MX 6 internal	USB Host1 data-
C25	GND	-	-	Ground 0 V
C26	X_PMIC_nSHUTDOWN	I	VDD_3V3	PMIC shutdown
C27	X_3V3_GOOD	0	VDD_MX6_SNVS	3V3 power good signal
C28	X_JTAG_TMS	I	VDD_3V3_LOGIC	JTAG TMS
C29	X_JTAG_TDO	0	VDD_3V3_LOGIC	JTAG TDO
C30	X_CSI_D0P	CSI2_I	i.MX 6 internal	MIPI/CSI-2 data0+
C31	X_CSI_D0M	CSI2_I	i.MX 6 internal	MIPI/CSI-2 data0-
C32	GND	-	-	Ground 0 V
C33	X_CSI_D2P	CSI2_I	i.MX 6 internal	MIPI/CSI-2 data2+
C34	X_CSI_D2M	CSI2_I	i.MX 6 internal	MIPI/CSI-2 data2-
C35	X_CSI_CLK0P	CSI2_I	i.MX 6 internal	MIPI/CSI-2 clock+
C36	X_CSI_CLK0M	CSI2_I	i.MX 6 internal	MIPI/CSI-2 clock-
C37	GND	-	-	Ground 0 V

Table 5: Pinout of the phyCORE-Connector X1, Row C

Pin #	Signal	ST	Voltage Domain	Description
C38	X_HDMI_CEC	I/O	VDD_3V3_LOGIC	HDMI CEC
C39	X_HDMI_CLKP	TDMS_0	i.MX 6 internal	HDMI clock+
C40	X_HDMI_CLKM	TDMS_0	i.MX 6 internal	HDMI clock-
C41	X_HDMI_D1P	TDMS_0	i.MX 6 internal	HDMI data1+
C42	X_HDMI_D1M	TDMS_0	i.MX 6 internal	HDMI data1-
C43	GND	-	-	Ground 0 V
C44	X_HDMI_DDC_SDA	I/O	VDD_3V3_LOGIC	HDMI DDC data
C45	X_CSI0_DAT18	I	VDD_3V3_LOGIC	IPU1_CSI0 data 18
C46	X_CSI0_DAT16	I	VDD_3V3_LOGIC	IPU1_CSI0 data 16
C47	X_CSI0_DAT14	I	VDD_3V3_LOGIC	IPU1_CSI0 data 14
C48	GND	-	-	Ground 0 V
C49	X_CSI0_DAT12	I	VDD_3V3_LOGIC	IPU1_CSI0 data 12
C50	X_CSI0_DAT10	I	VDD_3V3_LOGIC	IPU1_CSI0 data 10
C51	X_CSI0_DAT8	I	VDD_3V3_LOGIC	IPU1_CSI0 data 8
C52	X_CSI0_DAT6	I	VDD_3V3_LOGIC	IPU1_CSI0 data 6
C53	X_CSI0_DAT5	I	VDD_3V3_LOGIC	IPU1_CSI0 data 5
C54	GND	-	-	Ground 0 V
C55	X_CSI0_DAT4	I	VDD_3V3_LOGIC	IPU1_CSI0 data 4
C56	X_CSI0_PIXCLK	O	VDD_3V3_LOGIC	IPU1_CSI0 pixel clock
C57	X_FLEXCAN1_TX	O	VDD_3V3_LOGIC	FLEXCAN1 transmit
C58	GND	-	-	Ground 0 V
C59	X_LVDS0_TX1+	LVDS_0	i.MX 6 internal	LVDS0 data 1+
C60	X_LVDS0_TX1-	LVDS_0	i.MX 6 internal	LVDS0 data 1-
C61	X_LVDS0_TX0+	LVDS_0	i.MX 6 internal	LVDS0 data 0+
C62	X_LVDS0_TX0-	LVDS_0	i.MX 6 internal	LVDS0 data 0-
C63	GND	-	-	Ground 0 V
C64	X_LVDS0_TX3+	LVDS_0	i.MX 6 internal	LVDS0 data 3+
C65	X_LVDS0_TX3-	LVDS_0	i.MX 6 internal	LVDS0 data 3-
C66	X_LVDS1_CLK+	LVDS_0	i.MX 6 internal	LVDS1 clock+
C67	X_LVDS1_CLK-	LVDS_0	i.MX 6 internal	LVDS1 clock-
C68	GND	-	-	Ground 0 V
C69	X_LVDS1_TX0+	LVDS_0	i.MX 6 internal	LVDS1 data 0+
C70	X_LVDS1_TX0-	LVDS_0	i.MX 6 internal	LVDS1 data 0-

Table 5: Pinout of the phyCORE-Connector X1, Row C (continued)

Pin #	Signal	ST	Voltage Domain	Description
D1	X_BOOT_MODE1	I	VDD_3V3_LOGIC	Boot mode input 1
D2	X_ETH0_B+/RX0+	ETH_I	VDD_3V3_LOGIC	ETH0 data B+/receive+
D3	X_ETH0_B-/RX0-	ETH_I	VDD_3V3_LOGIC	ETH0 data B-/receive-
D4	X_ETH0_LED1	OC	VDD_3V3_LOGIC	ETH0 traffic LED output
D5	X_ETH0_D+	ETH_I/O	VDD_3V3_LOGIC	ETH0 data D+ (only GbE)
D6	X_ETH0_D-	ETH_I/O	VDD_3V3_LOGIC	ETH0 data D- (only GbE)
D7	GND	-	-	Ground 0 V
D8	X_SATA_RXP	LVDS_I	i.MX 6 internal	SATA PHY receive lane+
D9	X_SATA_RXN	LVDS_I	i.MX 6 internal	SATA PHY receive lane-
D10	X_PCIE_TXP	PCIE_0	i.MX 6 internal	PCIe transmit lane+
D11	X_PCIE_TXN	PCIE_0	i.MX 6 internal	PCIe transmit lane-
D12	GND	-	-	Ground 0 V
D13	X_KEY_COL2	I	VDD_3V3_LOGIC	Keypad column 2 ¹⁰
D14	X_PMIC_nONKEY	I	VDD_3V3	PMIC onkey input
D15	X_ONOFF	I	VDD_MX6_SNVS	i.MX 6 on/off input
D16	X_CCM_CLK01	O	VDD_3V3_LOGIC	CCM clock output 1
D17	X_USB_OTG_CHD_B	O	VDD_3V3_LOGIC	USB OTG charger detection
D18	GND	-	-	Ground 0 V
D19	X_USB_OTG_DP	USB_I/O	i.MX 6 internal	USB OTG data+
D20	X_USB_OTG_DN	USB_I/O	i.MX 6 internal	USB OTG data-
D21	X_USB_OTG_OC	I	VDD_3V3_LOGIC	USB OTG overcurrent input
D22	X_USB_H1_VBUS	PWR_I	5 V	USB Host1 VBUS input
D23	X_JTAG_TCK	I	VDD_3V3_LOGIC	JTAG clock input
D24	GND	-	-	Ground 0 V
D25	X_JTAG_TRSTB	I	VDD_3V3_LOGIC	JTAG reset input (low active)
D26	X_JTAG_TDI	I	VDD_3V3_LOGIC	JTAG TDI
D27	X_CSI_D1P	CSI2_I	i.MX 6 internal	MIPI/CSI-2 data1+
D28	X_CSI_D1M	CSI2_I	i.MX 6 internal	MIPI/CSI-2 data1-
D29	X_CSI_D3P	CSI2_I	i.MX 6 internal	MIPI/CSI-2 data3+
D30	X_CSI_D3M	CSI2_I	i.MX 6 internal	MIPI/CSI-2 data3-
D31	GND	-	-	Ground 0 V
D32	X_nRESET	OC_BI	VDD_3V3	Reset input/output (low active)
D33	X_HDMI_D2P	TDMS_0	i.MX 6 internal	HDMI data2+
D34	X_HDMI_D2M	TDMS_0	i.MX 6 internal	HDMI data2-
D35	X_HDMI_HPD	I	VDD_3V3_LOGIC	HDMI hot plug detect
D36	GND	-	-	Ground 0 V

Table 6: Pinout of the phyCORE-Connector X1, Row D

¹⁰: Signal not used by any other interface can be used as GPIO without harming other features of the phyCORE-i.MX 6 (section 10).

Pin #	Signal	ST	Voltage Domain	Description
D37	X_HDMI_D0P	TDMS_0	i.MX 6 internal	HDMI data0+
D38	X_HDMI_D0M	TDMS_0	i.MX 6 internal	HDMI data0-
D39	X_HDMI_DDC_SCL	I/O	VDD_3V3_LOGIC	HDMI DDC clock
D40	X_CSI0_DAT19	I	VDD_3V3_LOGIC	IPU1_CSI0 data 19
D41	X_CSI0_DAT17	I	VDD_3V3_LOGIC	IPU1_CSI0 data 17
D42	GND	-	-	Ground 0 V
D43	X_CSI0_DAT15	I	VDD_3V3_LOGIC	IPU1_CSI0 data 15
D44	X_CSI0_DAT13	I	VDD_3V3_LOGIC	IPU1_CSI0 data 13
D45	X_CSI0_DAT11	I	VDD_3V3_LOGIC	IPU1_CSI0 data 11
D46	X_CSI0_DAT9	I	VDD_3V3_LOGIC	IPU1_CSI0 data 9
D47	X_CSI0_DAT7	I	VDD_3V3_LOGIC	IPU1_CSI0 data 7
D48	X_CSI0_VSYNC	I	VDD_3V3_LOGIC	IPU1_CSI0 vertical sync
D49	GND	-	-	Ground 0 V
D50	X_CSI0_DATA_EN	O	VDD_3V3_LOGIC	IPU1_CSI0 data enable
D51	X_CSI0_HSYNC	I	VDD_3V3_LOGIC	IPU1_CSI0 horizontal sync
D52	X_AUD5_RXD	I/O	VDD_3V3_LOGIC	I ² S AUD5 receive data
D53	X_AUD5_TXC	I/O	VDD_3V3_LOGIC	I ² S AUD5 transmit clock
D54	X_AUD5_TXFS	I/O	VDD_3V3_LOGIC	I ² S AUD5 frame sync
D55	GND	-	-	Ground 0 V
D56	X_AUD5_TXD	I/O	VDD_3V3_LOGIC	I ² S AUD5 transmit data
D57	X_FLEXCAN1_RX	I	VDD_3V3_LOGIC	FLEXCAN1 receive
D58	X_LVDS0_CLK+	LVDS_0	i.MX 6 internal	LVDS0 clock+
D59	X_LVDS0_CLK-	LVDS_0	i.MX 6 internal	LVDS0 clock-
D60	X_LVDS0_TX2+	LVDS_0	i.MX 6 internal	LVDS0 data 2+
D61	X_LVDS0_TX2-	LVDS_0	i.MX 6 internal	LVDS0 data 2-
D62	GND	-	-	Ground 0 V
D63	X_LVDS1_TX2+	LVDS_0	i.MX 6 internal	LVDS1 data 2+
D64	X_LVDS1_TX2-	LVDS_0	i.MX 6 internal	LVDS1 data 2-
D65	X_LVDS1_TX1+	LVDS_0	i.MX 6 internal	LVDS1 data 1+
D66	X_LVDS1_TX1-	LVDS_0	i.MX 6 internal	LVDS1 data 1-
D67	GND	-	-	Ground 0 V
D68	X_LVDS1_TX3+	LVDS_0	i.MX 6 internal	LVDS1 data 3+
D69	X_LVDS1_TX3-	LVDS_0	i.MX 6 internal	LVDS1 data 3-
D70	X_TAMPER/ENET_RXC	I	VDD_3V3_LOGIC	Tamper or ENET_RXC signal of i.MX 6 ¹¹

Table 6: Pinout of the phyCORE-Connector X1, Row D (continued)

¹¹: selection of either Tamper, or ENET_RXC signal can be done with jumper J6 (Table 7)

3 Jumpers

For configuration purposes, the phyCORE-i.MX 6 has several solder jumpers, some of which have been installed prior to delivery. [Figure 5](#) illustrates the numbering of the solder jumper pads, while [Figure 6](#) and [Figure 7](#) indicate the location and the default configuration of the solder jumpers on the board.

[Table 7](#) below provides a functional summary of the solder jumpers which can be changed to adapt the phyCORE-i.MX 6 to your needs. It shows their default positions, and possible alternative positions and functions. A detailed description of each solder jumper can be found in the applicable chapter listed in the table.

Note:

Jumpers not listed should not be changed as they are installed with regard to the configuration of the phyCORE-i.MX 6.

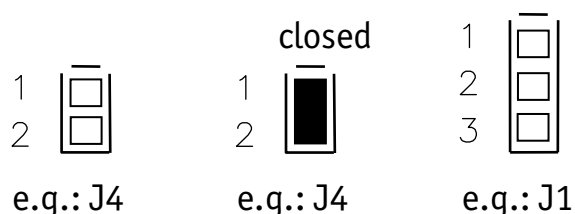

Figure 5: Typical Jumper Pad Numbering Scheme

If manual jumper modification is required please ensure that the board as well as surrounding components and sockets remain undamaged while de-soldering. Overheating the board can cause the solder pads to loosen, rendering the module inoperable. Carefully heat neighboring connections in pairs. After a few alternations, components can be removed with the solder-iron tip. Alternatively, a hot air gun can be used to heat and loosen the bonds.

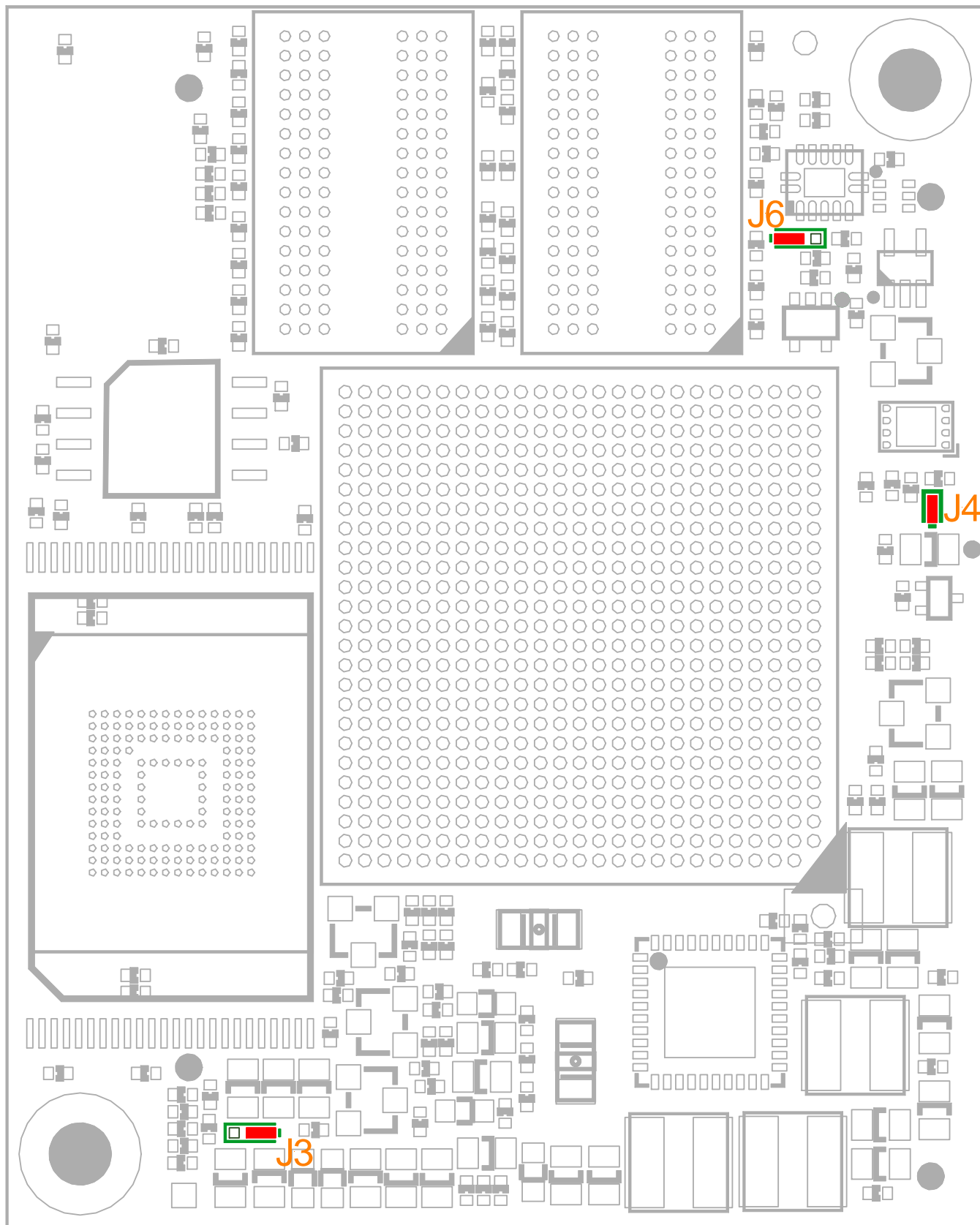

Figure 6: Jumper Locations (top view)

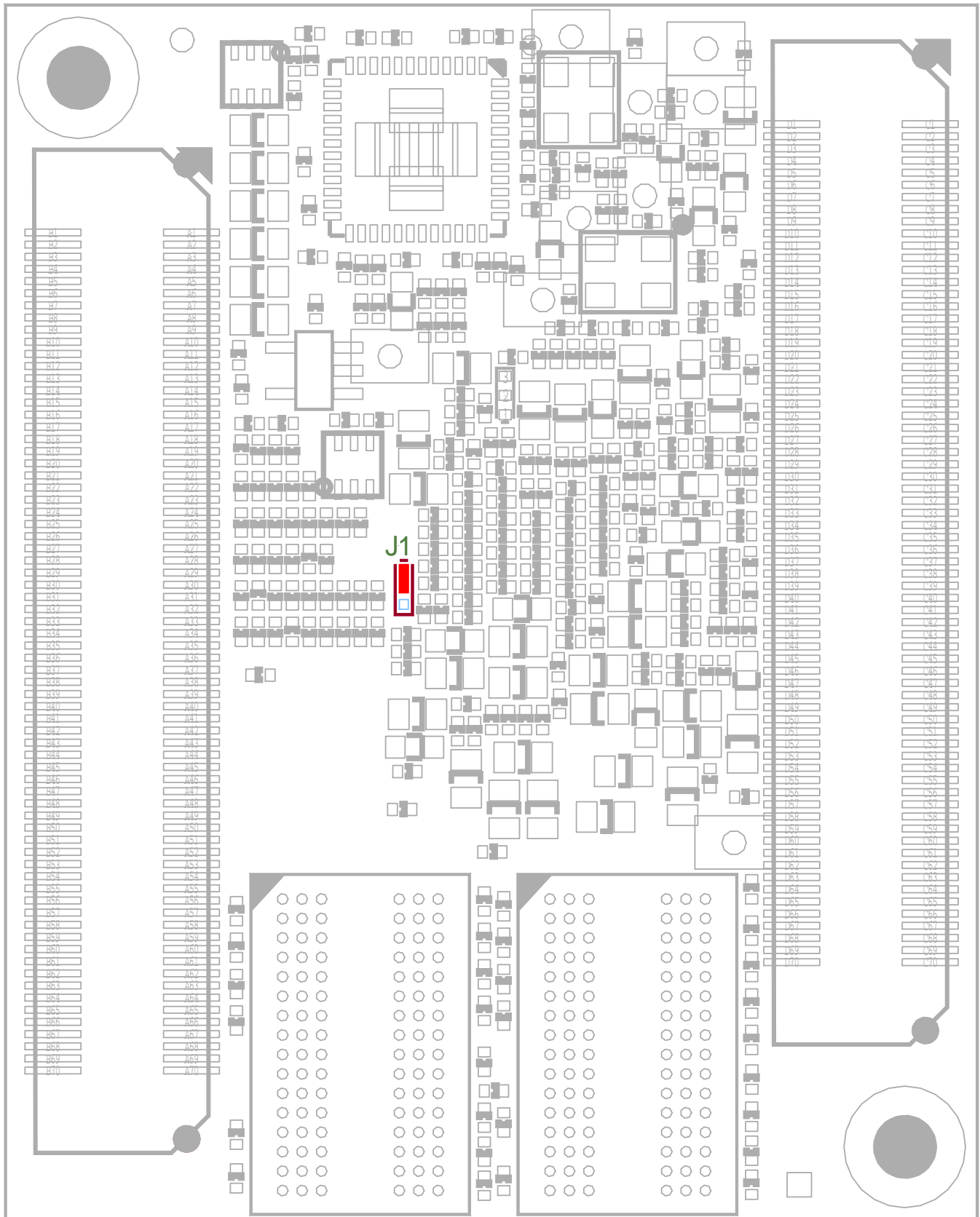

Figure 7: Jumper Locations (bottom view)

Please pay special attention to the “TYPE” column to ensure you are using the correct type of jumper (0 Ohms, 10k Ohms, etc...). The jumpers are 0402 package with a 1/8 W or better power rating.

The jumpers (J = solder jumper) have the following functions:

Jumper	Description	Type	Chapter
J4	J4 connects the write protect input of the on-board EEPROM with GND. If this jumper is not populated, the EEPROM is write protected.	0R (0402)	7.4.1
closed	EEPROM is not write protected		
open	EEPROM is write protected. The protection can be changed by the EEPROM_WP signal (GPIO1_13)		
J3	J3 defines which backup domain is supplied by the backup voltage input X1A5	0 Ω (0402)	4.4 16
1+2	PMIC backup domain is supplied		
2+3	i.MX 6 low power domain (SNVS_LP) is supplied		
J1	J1 selects the voltage source for the i.MX 6's power input NVCC_ENET (voltage domain VDD_ENET_IO)	0 Ω (0402)	9.4.4
1+2	VDD_ENET_IO is supplied by VDD_ETH_IO (2.5 V)		
2+3	VDD_ENET_IO is supplied by VDD_3V3_LOGIC (3.3 V)		
J6	J6 selects the signal which is brought out on pin X1D70 of the phyCORE-Connector	0 Ω (0402)	16
1+2	TAMPER signal of i.MX 6 is connected to phyCORE-Connector pin X1D70		
2+3	ENET_RXC signal of i.MX 6 is connected to phyCORE-Connector pin X1D70		

Table 7: Jumper Settings¹²

¹²: Default settings are in **bold blue** text

4 Power

The phyCORE-i.MX 6 operates off of a single power supply voltage.

The following sections of this chapter discuss the primary power pins on the phyCORE-Connector X1 in detail.

4.1 Primary System Power (VDD_3V3)

The phyCORE-i.MX 6 operates off of a primary voltage supply with a nominal value of +3.3 V. On-board switching regulators generate the 2.5 V, 1.375 V, 1.5 V, 0.75 V, 1.2 V and 3 V voltage supplies required by the i.MX 6 MCU and on-board components from the primary 3.3 V supplied to the SOM.

For proper operation the phyCORE-i.MX 6 must be supplied with a voltage source of 3.3 V \pm 5 % with 2.5 A load at the VCC pins on the phyCORE-Connector X1.

VDD_3V3: X1 A1, A2, A3, A4, B1, B2, B3, B4

Connect all +3.3 V VCC input pins to your power supply and at least the matching number of GND pins.

Corresponding GND: X1 A6, A11, A16, A21, B6, B12, B17, B22

Please refer to [section 2](#) for information on additional GND Pins located at the phyCORE-Connector X1.

Caution!

As a general design rule we recommend connecting all GND pins neighboring signals which are being used in the application circuitry. For maximum EMI performance all GND pins should be connected to a solid ground plane.

4.2 Power Management IC (PMIC) (U16)

The phyCORE-i.MX 6 provides an on-board Power Management IC (PMIC) at position U16 to generate different voltages required by the microcontroller and the on-board components. [Figure 8](#) presents a graphical depiction of the powering scheme.

The PMIC supports many functions like on-chip RTC and different power management functionalities like dynamic voltage control, different low power modes and regulator supervision. It is connected to the i.MX 6 via the on-board I²C bus (I2C3). The I²C address of the PMIC is 0x58 (page 0 and 1) and 0x59 (page 2 and 3).

4.2.1 Power Domains

External voltages:

- VDD_3V3 3.3 V main supply voltage
- USB0_VBUS USB0 Bus voltage, must be supplied with 5 V if USB0 is used
- USB1_VBUS USB1 Bus voltage, must be supplied with 5 V if USB1 is used
- VDD_BAT Backup supply (connected to PMIC_VBBAT or VDD_MX6_SNVS via J3 ([Table 7](#)))

Internally generated voltages: VDD_MX6_ARM (1.375 V), VDD_MX6_SOC (1.375 V), VDD_3V3_LOGIC (3.3 V), VDD_ETH_IO (2.5 V) VDD_MX6_SNVS (3.0 V), VDD_MX6_HIGH (3.0 V), VDD_eMMC_1V8 (1.8 V) VDD_ETH_1V2 (1.2 V), VDD_DDR3_1V5 (1.5 V), DDR3_VREF (0.75 V)

- VDD_MX6_ARM: i.MX 6 core (VDDARM_IN, VDDARM23_IN)
(1.375 V)
- VDD_MX6_SOC: i.MX 6 SOC (VDDSOC_IN)
(1.375 V)
- VDD_MX6_HIGH: i.MX 6 internal regulator (VDDHIGH_IN)
(3.0 V)
- VDD_MX6_SNVS: i.MX 6 backup supply (VDD_SNVS_IN)
(3.0 V)
- VDD_ETH_IO: i.MX 6 RGMII supply (NVCC_RGMII, NVCC_ENET¹³),
(2.5 V) Ethernet PHY RGMII IO supply
- VDD_ETH_1V2: Ethernet PHY core voltage
(1.2 V)
- VDD_DDR3_1V5: i.MX 6 DDR interface (NVCC_DRAM), RAM devices
(1.5 V)
- VDD_eMMC_1V8: 1.8V eMMC supply
(1.8 V)
- DDR3_VREF: i.MX 6 DDR3 reference voltage (DRAM_VREF), RAM devices
(0.75 V) reference voltage
- VDD_3V3_LOGIC: i.MX 6 pad supply (NVCC_NANDF, NVCC_JTAG, NVCC_LCD,
(3.3 V) NVCC_CSI, NVCC_EIM, NVCC_SD, NVCC_GPIO, (NVCC_ENET¹³)),
I²C EEPROM, SPI Flash, NAND Flash, eMMC, Ethernet PHY,
User LED, reference output X1B5

¹³: NVCC_ENET is connected via jumper J1 and can alternatively be supplied by VDD_3V3_LOGIC ([section 9.4.4](#))

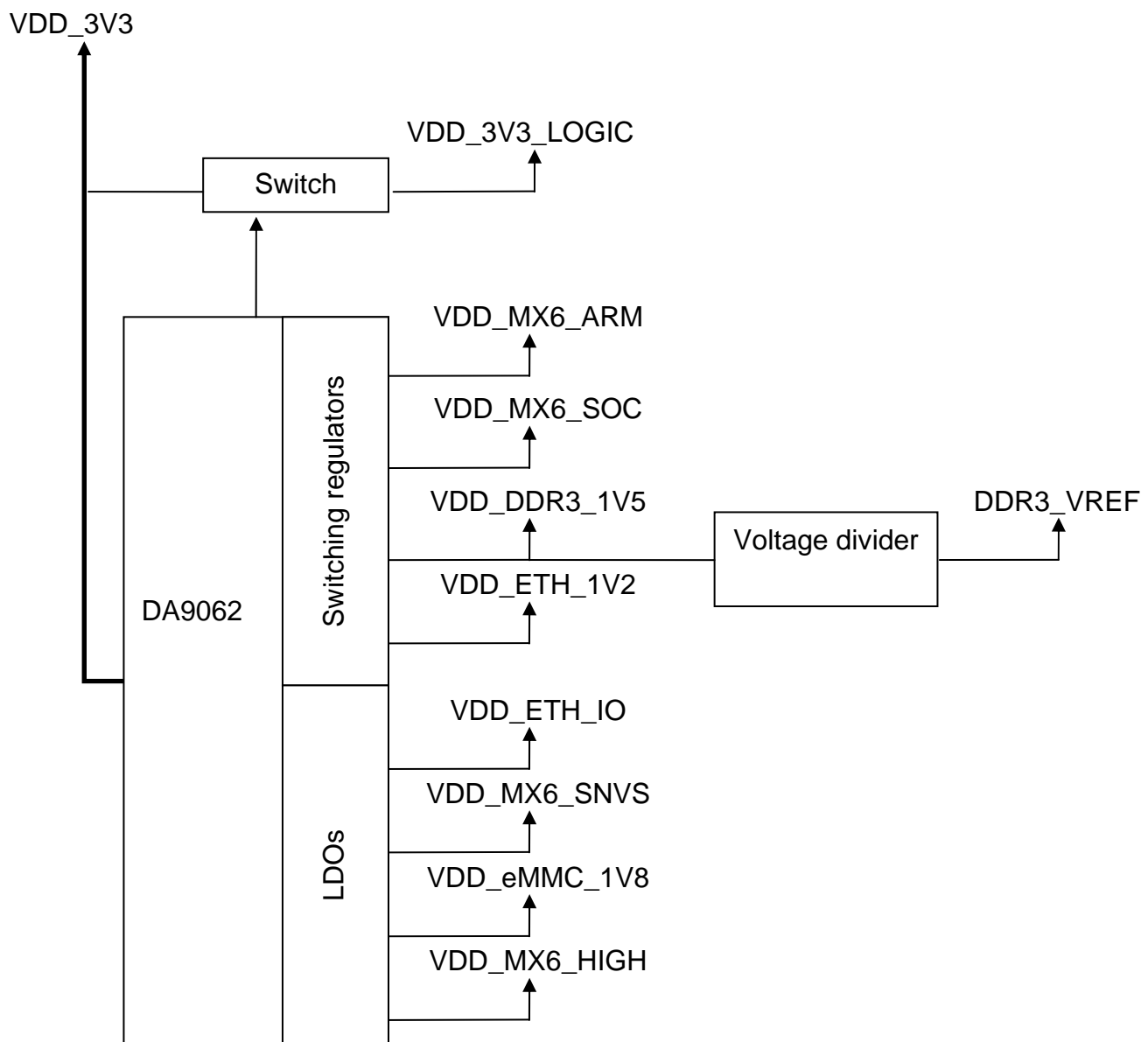

Figure 8: Powering Scheme of the phyCORE-i.MX 6

4.3 Supply Voltage for external Logic

The voltage level of the phyCORE's logic circuitry is VDD_3V3_LOGIC (3.3 V) which is derived from the main input voltage VDD_3V3 of the SOM. In order to follow the power-up and power-down sequencing mandatory for the i.MX 6 external devices have to be supplied by the I/O supply voltage VDD_3V3_LOGIC which is brought out at pin X1B5 of the phyCORE-Connector. Use of VDD_3V3_LOGIC ensures that external components are only supplied when the supply voltages of the i.MX 6 are stable.

Caution!

- The current draw for VDD_3V3_LOGIC must not exceed 500 mA. Consequently this voltage should only be used as reference, or supply voltage for level shifters, and not for supplying purpose. If devices with a higher power consumption are to be connected to the phyCORE-i.MX 6 their supply voltage should be switched on and off by use of the X_3V3_GOOD signal. This way the power-up and power-down sequencing will be considered even if the devices are not supplied directly by VDD_3V3_LOGIC.

If used to control, or supply bus switches on the phyCORE side VDD_3V3_LOGIC also serves to strictly separate the supply voltages generated on the phyCORE-i.MX 6 and the supply voltages used on the carrier board/custom application. That way, voltages at the IO pins of the phyCORE-i.MX 6 which are sourced from the supply voltage of peripheral devices attached to the SOM are avoided. These voltages can cause a current flow into the controller especially if peripheral devices attached to the interfaces of the i.MX 6 are supposed to be powered while the phyCORE-i.MX 6 is in suspend mode, or turned off. The bus switches can either be supplied by VDD_3V3_LOGIC on the phyCORE side, or the bus switches' output enable to the SOM can be controlled by X_3V3_GOOD to prevent these voltages from occurring.

Use of level shifters supplied with VDD_3V3_LOGIC allows converting the signals according to the needs on the custom target hardware. Alternatively signals can be connected to an open drain circuitry with a pull-up resistor attached to VDD_3V3_LOGIC.

4.4 Backup Power (PMIC_VBAT/VDD_MX6_SNVS)

To backup the PMIC's RTC and some of its critical registers, or the i.MX 6's low power domain (SNVS_LP) and its RTC, a secondary voltage source of 3 V can be attached to the phyCORE-i.MX 6 at pin X1A5. Jumper J3 selects either the backup voltage domain PMIC_VBAT (J3:1+2) or the i.MX6's voltage domain VDD_MX6_SNVS (J3:2+3) to be supplied when the primary system power (VDD_3V3) is removed.

5 Reset

Pin X1D32 on the phyCORE-Connector is designated as reset input/output.

If used as reset input a hard reset of the module can be triggered. In this case the external reset signal is connected to the nRESETREQ signal of the DA9062 PMIC which triggers a hard reset of the module with a debouncing time of 10.24 ms.

When used as reset output, the nRESET signal of the DA9062 PMIC is brought out to allow resetting devices on the carrier board.

In case of a hard reset, no matter if it was triggered externally or internally, the PMIC holds down the nRESET signal until the module voltages are generated. The nRESET signal is released 2 ms after the last module voltage is generated correctly.

6 System Configuration and Booting

Although most features of the i.MX 6 microcontroller are configured and/or programmed during the initialization routine, other features, which impact program execution, must be configured prior to initialization via pin termination.

The system start-up configuration includes:

- Boot mode selection
- Boot device selection
- Boot device configuration

The internal ROM code is the first code executed during the initialization process of the i.MX 6 after POR. The ROM code detects the boot mode by using the boot mode pins (BOOT_MODE[1:0]), while the boot device is selected and configured by determining the state of the eFUSES and/or the corresponding GPIO input pins (BOOT_CFGx[7:0]).

6.1 Boot Mode Selection

The boot mode of the i.MX 6 microcontroller is determined by the configuration of two boot mode inputs BOOT_MODE[1:0] during the reset cycle of the operational system. These inputs are brought out at the phyCORE-Connector pins X_BOOT_MODE[1:0] (X1D1, X1C1).

Table 8 shows the possible settings of pins X_BOOT_MODE0 (X1C1) and X_BOOT_MODE1 (X1D1) and the resulting boot configuration of the i.MX 6.

Boot Mode	X_BOOT_MODE1	X_BOOT_MODE0	Boot Source
0	0	0	Bootconfig from eFUSES
1	0	1	Serial Downloader
2	1	0	Internal Boot¹⁴
3	1	1	reserved

Table 8: Boot Modes of the phyCORE-i.MX 6

The BOOT_MODE[1:0] lines have 10 kΩ pull-up and pull-down resistors populated on the module. Hence leaving the two pins unconnected sets the controller to boot mode 2, internal boot.

¹⁴: Default boot mode when pins X_BOOT_MODE[1:0] are left unconnected.

For serial boot (boot mode = 1) the ROM code polls the communication interface selected, initiates the download of the code into the internal RAM and triggers its execution from there. Please refer to the *i.MX 6 Reference Manual* for more information.

In boot mode 0 and 2 the ROM code finds the bootstrap in permanent memories such as NAND-Flash or SD-Cards and executes it. The selection of the boot device and the configuration of the interface required are accomplished with the help of the eFUSES and/or the corresponding GPIO input pins.

6.2 Boot Device Selection and Configuration

In normal operation (boot mode 0, or 2), the boot ROM uses the state of BOOT_MODE and eFUSES to determine the boot device.

During development it is advisable to set the boot type to “Internal boot” (BOOT_MODE[1:0]=10¹⁴ to allow choosing and configuring the boot device by using GPIO pin inputs. The input pins are sampled at boot, and override the values of the corresponding eFUSES BOOT_CFGx[7:0], if the BT_FUSE_SEL fuse is not blown.

[Table 9](#) lists the eFUSES BOOT_CFGx[7:0] and the corresponding input pins.

On the phyCORE-i.MX 6 the GPIOs have 10 kΩ pull-up and pull-down resistors preinstalled to configure eFUSES BOOT_CFGx[7:0] in accordance with the module features.

However, the specific boot configuration settings, which are set by the on-board configuration resistors, can be changed by modifying the resistors on the module or by connecting a configuration resistor (e.g. 10 kΩ) to the configuration signal. Please consider that any change of the default BCFG configuration can also influence other boot modes, which might result in faulty boot behavior.

Caution!

Please make sure that the signals shown in [Table 9](#) are not driven by any device on the baseboard during reset, to avoid accidental change of the boot configuration.

Because of this, we recommend to boot from eFUSE for volume production and use only internal boot mode for development process¹⁵.

Please refer to the *i.MX 6 Reference Manual* for further information about the eFUSES and the impact of the settings at the BCFG pins.

¹⁵: For series production Phytec offers to order the phyCORE-i.MX 6 with a custom configuration of the eFUSES

Configuration Pin	Pin #	Signal	ST	SL	Description
BCFG1[0]	X1A30	X_CSI1_DATA09	I	3.3 V	IPU2_CSI1 data 9
BCFG1[1]	X1A32	X_CSI1_DATA08	I	3.3 V	IPU2_CSI1 data 8
BCFG1[2]	X1B39	X_CSI1_DATA07	I	3.3 V	IPU2_CSI1 data 7
BCFG1[3]	X1B40	X_CSI1_DATA06	I	3.3 V	IPU2_CSI1 data 6
BCFG1[4]	X1B41	X_CSI1_DATA05	I	3.3 V	IPU2_CSI1 data 5
BCFG1[5]	X1B42	X_CSI1_DATA04	I	3.3 V	IPU2_CSI1 data 4
BCFG1[6]	X1A33	X_CSI1_DATA03	I	3.3 V	IPU2_CSI1 data 3
BCFG1[7]	X1A34	X_CSI1_DATA02	I	3.3 V	IPU2_CSI1 data 2
BCFG2[0]	X1A37	X_CSI1_DATA01	I	3.3 V	IPU2_CSI1 data 1
BCFG2[1]	X1A38	X_CSI1_DATA00	I	3.3 V	IPU2_CSI1 data 0
BCFG2[2]	X1A35	X_CSI1_DATA_EN	O	3.3 V	IPU2_CSI1 data enable
BCFG2[3]	X1A40	X_CSI1_HSYNC	I	3.3 V	IPU2_CSI1 horizontal sync
BCFG2[4]	X1A39	X_CSI1_VSYNC	I	3.3 V	IPU2_CSI1 vertical sync
BCFG2[5]	X1A25	X_EIM_DA13	I/O	3.3 V	EIM address/data 13
BCFG2[6]	X1B26	X_EIM_DA14	I/O	3.3 V	EIM address/data 14
BCFG2[7]	X1B27	X_EIM_DA15	I/O	3.3 V	EIM address/data 15
BCFG3[0]	X1B36	X_CSI1_PIXCLK	O	3.3 V	IPU2_CSI1 pixel clock
BCFG3[1]	X1A27	X_CSI1_DATA12	I	3.3 V	IPU2_CSI1 data 12
BCFG3[2]	X1B37	X_CSI1_DATA13	I	3.3 V	IPU2_CSI1 data 13
BCFG3[3]	X1B35	X_CSI1_DATA14	I	3.3 V	IPU2_CSI1 data 14
BCFG3[4]	X1B34	X_CSI1_DATA15	I	3.3 V	IPU2_CSI1 data 15
BCFG3[5]	X1B32	X_CSI1_DATA16	I	3.3 V	IPU2_CSI1 data 16
BCFG3[6]	X1B31	X_CSI1_DATA17	I	3.3 V	IPU2_CSI1 data 17
BCFG3[7]	X1B30	X_CSI1_DATA18	I	3.3 V	IPU2_CSI1 data 18
BCFG4[0]	X1B29	X_CSI1_DATA19	I	3.3 V	IPU2_CSI1 data 19
BCFG4[1]		EIM_WAIT	not available at phyCORE-Connector ¹⁶		
BCFG4[2]	X1A44	X_ECSPi2_SS1	I/O	3.3 V	eCSPI2 chip select 1
BCFG4[3]	X1A28	X_CSI1_DATA11	I	3.3 V	IPU2_CSI1 data 11
BCFG4[4]	X1B44	X_EIM_EB1	O	3.3 V	EIM enable byte 1
BCFG4[5]	X1A45	X_ECSPi2_SS0	I/O	3.3 V	eCSPI2 chip select 0
BCFG4[6]	X1A24	X_ECSPi1_SS0	I/O	3.3 V	eCSPI1 chip select 0
BCFG4[7]	X1A20	X_UART3_RTS_B	I	3.3 V	UART3 request to send input

Table 9: Boot Configuration Pins at the phyCORE-Connector

¹⁶: Connected to GND for the standard module configuration

7 System Memory

The phyCORE-i.MX 6 provides four types of on-board memory:

- 1 Bank DDR3 RAM: 512 GB DDR3 SDRAM (up to 2 GB)¹⁷
- NAND Flash (TSOP) : 256 MB (up to 16 GB)¹⁷,
alternatively eMMC 2 GB (up to 32 GB)¹⁷
- I²C-EEPROM: 4 kB¹⁷
- SPI Flash: 16 MB¹⁷

The following sections of this chapter detail each memory type used on the phyCORE-i.MX 6.

7.1 DDR3-SDRAM (U4-U7)

The RAM memory of the phyCORE-i.MX 6 is comprised of one 64 bit wide bank with four 16-bit wide DDR3-SDRAM chips (U4-U7). The chips are connected to the special DDR interface called Multi Mode DDR Controller (MMDC) of the i.MX 6 microcontroller.

The DDR3 memory is accessible starting at address 0x1000 0000.

Typically the DDR3-SDRAM initialization is performed by a boot loader or operating system following a power-on reset and must not be changed at a later point by any application code. When writing custom code independent of an operating system or boot loader, the SDRAM must be initialized by accessing the appropriate SDRAM configuration registers on the i.MX 6 controller. Refer to the *i.MX 6 Reference Manual* for accessing and configuring these registers.

¹⁷: The maximum memory size listed is as of the printing of this manual. Please contact PHYTEC for more information about additional, or new module configurations available.

7.2 NAND Flash Memory (U12)

Use of Flash as non-volatile memory on the phyCORE-i.MX 6 provides an easily reprogrammable means of code storage.

The NAND Flash memory at U12 is connected to the General Purpose Media Interface (GPMI). Dependent on the memory size one or more of the chip enable signals NANDF_CS0, NANDF_CS1, NANDF_CS2 and NANDF_CS3 of the GPMI interface select the NAND Flash.

The Flash devices are programmable with 3.3 V. No dedicated programming voltage is required.

As of the printing of this manual these NAND Flash devices generally have a life expectancy of at least 100,000 erase/program cycles and a data retention rate of 10 years.

Any parts that are footprint (TSOP-48-50-C3) and functionally compatible may be used with the phyCORE-i.MX 6.

7.3 eMMC Flash Memory (U14)

Alternatively to the NAND flash memory at U12, an eMMC can be populated at U14.

The eMMC device is programmable with 3.3 V. No dedicated programming voltage is required.

The eMMC Flash memory is connected to the SD4 interface of the i.MX 6.

Any parts that are footprint (BGA153) and functionally compatible may be used with the phyCORE-i.MX 6.

7.4 I²C EEPROM (U11)

The phyCORE-i.MX 6 is populated with a non-volatile 4 kB I²C¹⁸ EEPROM at U11. This memory can be used to store configuration data or other general purpose data. This device is accessed through I²C port 3 on the i.MX 6. The control registers for I²C port 3 are mapped between addresses 0x021A 8000 and 0x021A BFFF. Please see the *i.MX 6 Reference Manual* for detailed information on the registers.

The three lower address bits are fixed to zero which means that the EEPROM can be accessed at I²C address 0x50.

Write protection to the device is accomplished via jumper J4. Refer to [section 7.4.1](#) for further details.

¹⁸: See the manufacturer's data sheet for interfacing and operation.

7.4.1 EEPROM Write Protection Control (J4)

Jumper J4 controls write access to the EEPROM (U11) device. Closing this jumper allows write access to the device, while removing this jumper will cause the EEPROM to enter write protect mode, thereby disabling write access to the device.

The following configurations are possible:

EEPROM Write Protection State	J4
Write access allowed	closed
EEPROM is write protected. The protection can be changed by the EEPROM_WP signal (GPIO1_13)	open

Table 10: EEPROM write protection states via J4¹⁹

7.5 SPI Flash Memory (U9)

The SPI Flash Memory of the phyCORE-i.MX 6 at U9 can be used to store configuration data or any other general purpose data. Beside this it can also be used as boot device²⁰ and recovery boot device²⁰. The device is accessed through eCSPI1 SS1 on the i.MX 6. The control registers for eCSPI1 are mapped between addresses 0x0200 8000 and 0x0200 BFFF. Please see the *i.MX 6 Reference Manual* for detailed information on the registers.

The SPI Flash can be write protected. The active low signal SPI_NOR_nWP/GPIO1_12 connects to GPIO1_12 of the i.MX 6 and allows to control the SPI Flash's write-protection.

As of the printing of this manual these SPI Flash devices generally have a life expectancy of at least 100,000+ erase/program cycles and a data retention rate of 20 years. This makes the SPI Flash a reliable and secure solution to store the first and second level bootloaders.

¹⁹: Defaults are in **bold blue** text

²⁰: The standard boot configuration selects the SPI Flash as recovery boot device. To use it as boot device the boot configuration, or the eFUSES must be changed.

8 SD / MM Card Interfaces

The phyCORE bus features two SD / MM Card interface. On the phyCORE-i.MX 6 the interface signals extend from the controllers third and first Ultra Secured Digital (uSDHC3 / uSDHC1) Host Controller to the phyCORE-Connector. [Table 11](#) shows the location of the different interface signals on the phyCORE-Connector. The MMC/SD/SDIO Host Controller is fully compatible with the SD Memory Card Specification 3.0 and SD I/O Specification, Part E1, v1.10. SDC / MMC interface SD3 (uSDHC3 of the i.MX 6), supports 8 data channels and SD1 (uSDHC1 of the i.MX 6) 4 data channels. Both interfaces have a maximum data rate of up to 104 MB/s (refer to the *i.MX 6 Reference Manual* for more information).

Pin #	Signal	ST	Voltage Domain	Description
X1A7	X_SD3_CMD	0	VDD_3V3_LOGIC	uSDHC3 command
X1A8	X_SD3_DATA0	I/O	VDD_3V3_LOGIC	uSDHC3 data 0
X1A9	X_SD3_DATA2	I/O	VDD_3V3_LOGIC	uSDHC3 data 2
X1A10	X_SD3_DATA5	I/O	VDD_3V3_LOGIC	uSDHC3 data 5
X1A12	X_SD3_DATA7	I/O	VDD_3V3_LOGIC	uSDHC3 data 7
X1A13	X_SD3_RESET	0	VDD_3V3_LOGIC	uSDHC3 reset
X1B7	X_SD3_CLK	0	VDD_3V3_LOGIC	uSDHC3 clock
X1B8	X_SD3_DATA1	I/O	VDD_3V3_LOGIC	uSDHC3 data 1
X1B9	X_SD3_DATA3	I/O	VDD_3V3_LOGIC	uSDHC3 data 3
X1B10	X_SD3_DATA4	I/O	VDD_3V3_LOGIC	uSDHC3 data 4
X1B11	X_SD3_DATA6	I/O	VDD_3V3_LOGIC	uSDHC3 data 6
X1A14	X_SD1_DATA0	I/O	VDD_3V3_LOGIC	uSDHC1 data 0
X1A15	X_SD1_DATA2	I/O	VDD_3V3_LOGIC	uSDHC1 data 2
X1B13	X_SD1_CLK	0	VDD_3V3_LOGIC	uSDHC1 clock
X1B14	X_SD1_CMD	0	VDD_3V3_LOGIC	uSDHC1 command
X1B15	X_SD1_DATA1	I/O	VDD_3V3_LOGIC	uSDHC1 data 1
X1B16	X_SD1_DATA3	I/O	VDD_3V3_LOGIC	uSDHC1 data 3

Table 11: Location of the SD / MM Card Interface Signals

The interfaces do not provide dedicated card detect or write protect signals. The card detect and write protect function can be implemented easily by using four GPIOs of the i.MX 6.

9 Serial Interfaces

The phyCORE-i.MX 6 provides numerous dedicated serial interfaces some of which are equipped with a transceiver to allow direct connection to external devices:

1. Two High speed UARTs (TTL, derived from UART2 and UART3 of the i.MX 6) with up to 4 MHz and one with hardware flow control (RTS and CTS signals)
2. High speed USB OTG interface (extended directly from the i.MX 6's USB OTG PHY (USBPHY1))
3. High speed USB HOST interface (extended directly from the i.MX 6 USB HOST PHY (USBPHY2))
4. Auto-MDIX enabled 10/100/1000 Mbit Ethernet interface
5. One I²C interface (derived from I²C port 1 of the i.MX 6)
6. Two Serial Peripheral Interface (SPI) interface (extended from the first and second SPI module (eCSPI1 and eCSPI2) of the i.MX 6)
7. I²S audio interface (originating from the i.MX 6's Synchronous Serial Interface (SSI) and muxed through port 5 of the Digital Audio Multiplexer (AUDMUX5))
8. CAN 2.0B interface (extended directly from the i.MX 6 FlexCAN1 module)
9. SATA II, 3.0 Gbps (extended directly from the i.MX 6 SATA PHY)
10. PCI Express Gen. 2.0 (extended directly from the i.MX 6 PCIe PHY)

The following sections of this chapter detail each of these serial interfaces and any applicable configuration jumpers.

9.1 Universal Asynchronous Interface

The phyCORE-i.MX 6 provides two high speed universal asynchronous interfaces with up to 4 MHz and one with additional hardware flow control (RTS and CTS signals). The following table shows the location of the signals on the phyCORE-Connector.

Pin #	Signal	ST	Voltage Domain	Description
X1A17	X_UART2_RX_DATA	I	VDD_3V3_LOGIC	UART2 serial data receive
X1B21	X_UART2_TX_DATA	O	VDD_3V3_LOGIC	UART2 serial transmit signal
X1A18	X_UART3_RX_DATA	I	VDD_3V3_LOGIC	UART3 serial data receive
X1A19	X_UART3_CTS_B	O	VDD_3V3_LOGIC	UART3 clear to send output
X1A20	X_UART3_RTS_B	I	VDD_3V3_LOGIC	UART3 request to send input ²¹
X1B18	X_UART3_TX_DATA	O	VDD_3V3_LOGIC	UART3 serial transmit signal

Table 12: Location of the UART Signals

The signals extend from UART2 respectively UART3 of the i.MX 6 directly to the phyCORE-Connector without conversion to RS-232 level. External RS-232 transceivers must be attached by the user if RS-232 levels are required.

²¹: Special care must be taken not to override the device configuration when using this pin as input ([section 6.2](#)).

9.2 USB OTG Interface

The phyCORE-i.MX 6 provides a high speed USB OTG interface which uses the i.MX 6 embedded HS USB OTG PHY. An external USB Standard-A (for USB host), USB Standard-B (for USB device), or USB mini-AB (for USB OTG) connector is all that is needed to interface the phyCORE-i.MX 6 USB OTG functionality. The applicable interface signals can be found on the phyCORE-Connector X1 as shown in [Table 13](#).

Pin #	Signal	ST	Voltage Domain	Description
X1C18	X_USB_OTG_ID	I	VDD_3V3_LOGIC	USB OTG ID Pin
X1C19	X_USB_OTG_VBUS	PWR_I	5 V	USB OTG VBUS input
X1C20	X_USB_OTG_PWR	0	VDD_3V3_LOGIC	USB OTG power enable
X1D17	X_USB_OTG_CHD_B	0	VDD_3V3_LOGIC	USB OTG charger detection
X1D19	X_USB_OTG_DP	USB_I/O	i.MX 6 internal	USB OTG data+
X1D20	X_USB_OTG_DN	USB_I/O	i.MX 6 internal	USB OTG data-
X1D21	X_USB_OTG_OC	I	VDD_3V3_LOGIC	USB OTG overcurrent input

Table 13: Location of the USB OTG Signals

Caution!

X_USB_OTG_VBUS must be supplied with 5 V for proper USB functionality.

9.3 USB Host Interface

The phyCORE-i.MX 6 provides a high speed USB host interface which uses the i.MX 6 embedded HS USB host PHY.

An external USB Standard-A (for USB host) connector is all that is needed to interface the phyCORE-i.MX 6 USB host functionality. The applicable interface signals (D+/D- and VBUS) can be found on the phyCORE-Connector X1.

If overcurrent and power enable signals are needed for the USB host interface, the functionality can be easily implemented with GPIOs.

Pin #	Signal	ST	Voltage Domain	Description
X1C23	X_USB_H1_DP	USB_I/O	i.MX 6 internal	USB Host1 data+
X1C24	X_USB_H1_DN	USB_I/O	i.MX 6 internal	USB Host1 data-
X1D22	X_USB_H1_VBUS	PWR_I	5 V	USB Host1 VBUS input

Table 14: Location of the USB Host Signals

Caution!

X_USB_H1_VBUS must be supplied with 5 V for proper USB functionality.

9.4 Ethernet Interface

Connection of the phyCORE-i.MX 6 to the world wide web or a local area network (LAN) is possible using the on-board GbE PHY at U2. It is connected to the RGMII interface of the i.MX 6. The PHY operates with a data transmission speed of 10 Mbit/s, 100 Mbit/s or 1000 Mbit/s.

Alternatively the RMII (ENET) interface which is available on the phyCORE-Connector can be used to connect an external PHY. In this case, the on-board GbE PHY (U2) must not be populated ([section 9.4.4](#)).

9.4.1 Ethernet PHY (U2)

With an Ethernet PHY mounted at U2 the phyCORE-i.MX 6 has been designed for use in 10Base-T, 100Base-T and 1000Base-T networks. The 10/100/1000Base-T interface with its LED signals extends to the phyCORE-Connector X1.

Pin #	Signal	ST	Voltage Domain	Description
X1C2	X_ETH0_A+/TX0+	ETH_0	VDD_3V3_LOGIC	ETH0 data A+/transmit+
X1C3	X_ETH0_A-/TX0-	ETH_0	VDD_3V3_LOGIC	ETH0 data A-/transmit-
X1C5	X_ETH0_C+	ETH_I/O	VDD_3V3_LOGIC	ETH0 data C+ (only GbE)
X1C6	X_ETH0_C-	ETH_I/O	VDD_3V3_LOGIC	ETH0 data C- (only GbE)
X1C7	X_ETH0_LED0	OC	VDD_3V3_LOGIC	ETH0 link LED output
X1D2	X_ETH0_B+/RX0+	ETH_I	VDD_3V3_LOGIC	ETH0 data B+/receive+
X1D3	X_ETH0_B-/RX0-	ETH_I	VDD_3V3_LOGIC	ETH0 data B-/receive-
X1D4	X_ETH0_LED1	OC	VDD_3V3_LOGIC	ETH0 traffic LED output
X1D5	X_ETH0_D+	ETH_I/O	VDD_3V3_LOGIC	ETH0 data D+ (only GbE)
X1D6	X_ETH0_D-	ETH_I/O	VDD_3V3_LOGIC	ETH0 data D- (only GbE)

Table 15: Location of the Ethernet Signals

The on-board GbE PHY supports HP Auto-MDIX technology, eliminating the need for the consideration of a direct connect LAN cable, or a cross-over patch cable. It detects the TX and RX pins of the connected device and automatically configures the PHY TX and RX pins accordingly. The Ethernet PHY also features an Auto-negotiation to automatically determine the best speed and duplex mode.

The Ethernet PHY is connected to the RGMII interface of the i.MX 6. Please refer to the *i.MX 6 Reference Manual* for more information about this interface.

In order to connect the module to an existing 10/100/1000Base-T network some external circuitry is required. The required termination resistors on the analog signals (ETH0_A±, ETH0_B±, ETH0_C±, ETH0_D±) are integrated in the chip, so there is no need to connect external termination resistors to these signals. Connection to an external Ethernet magnetics should be done using very short signal traces. The A+/A-, B+/B-, C+/C- and D+/D- signals should be routed as 100 Ohm differential pairs. The same applies for the signal lines after the transformer circuit. The carrier board layout should avoid any other signal lines crossing the Ethernet signals.

Caution!

Please see the datasheet of the Ethernet PHY when designing the Ethernet transformer circuitry or request the schematic of the applicable carrier board (phyBOARD-Mira i.MX 6) as reference.

9.4.2 Software Reset of the Ethernet Controller

The Ethernet PHY at U2 can be reset by software. The reset input of the Ethernet PHY is permanently connected to pad SD2_DAT1 (GPIO1_14) of the i.MX 6.

9.4.3 MAC Address

In a computer network such as a local area network (LAN), the MAC (Media Access Control) address is a unique computer hardware number. For a connection to the Internet, a table is used to convert the assigned IP number to the hardware's MAC address.

In order to guarantee that the MAC address is unique, all addresses are managed in a central location. PHYTEC has acquired a pool of MAC addresses. The MAC address of the phyCORE-i.MX 6 is located on the bar code sticker attached to the module. This number is a 12-digit HEX value.

9.4.4 RMII Interface

In order to use an external Ethernet PHY instead of the on-board GbE PHY at U2 the RMII interface (ENET) of the i.MX 6 is brought out at phyCORE-Connector X1.

Caution!

The GbE PHY (U2) must not be populated on the module if the RMII interface is used.

Note:

In order to have the same signal level at all pins when using the RMII interface jumper J1 should be closed at 2+3. Closing jumper J1 at 2+3 connects the i.MX 6's power input NVCC_ENET (voltage domain VDD_ENET_IO) to VDD_3V3_LOGIC (3.3 V) instead of VDD_ETH_IO (2.5 V) ([Table 7](#)).

Pin #	Signal	ST	Voltage Domain	Description
X1A65	X_ENET_REFCLK	I	VDD_3V3_LOGIC	ENET RMII reference clock
X1A67	X_ENET_TXER	O	VDD_3V3_LOGIC	ENET MII transmit error
X1A68	X_ENET_RXD0	I	VDD_ENET_IO	ENET RMII receive data 0
X1A69	X_ENET_RXD1	I	VDD_ENET_IO	ENET RMII receive data 1
X1A70	X_ENET_RX_ER	I	VDD_ENET_IO	ENET RMII receive error
X1B19	X_ENET_MDIO	I/O	VDD_ENET_IO	ENET management data I/O
X1B20	X_ENET_MDC	O	VDD_ENET_IO	ENET management data clock
X1B66	X_ENET_CRSDV	I	VDD_ENET_IO	ENET RMII RX enable
X1B67	X_ENET_TXEN	O	VDD_ENET_IO	ENET RMII TX enable
X1B69	X_ENET_TXD0	O	VDD_ENET_IO	ENET RMII transmit data 0
X1B70	X_ENET_TXD1	O	VDD_ENET_IO	ENET RMII transmit data 1

Table 16: Location of the RMII Interface Signals

9.5 SPI Interface

The Serial Peripheral Interface (SPI) interface is a four-wire, bidirectional serial bus that provides a simple and efficient method for data exchange among devices. The phyCORE provides two SPI interfaces on the phyCORE-Connector X1. The SPI interfaces provide one respectively two chip select signals. The Enhanced Configurable SPI (eCSPI) of the i.MX 6 has five separate modules (eCSPI1, eCSPI2, eCSPI3, eCSPI4 and eCSPI5) which support data rates of up to 20 Mbit/s. The interface signals of the first and second module (eCSPI1, eCSPI2) are made available on the phyCORE-Connector. These modules are master/slave configurable. The following table lists the SPI signals on the phyCORE-Connector.

Pin #	Signal	ST	Voltage Domain	Description
X1A22	X_ECSP11_SCLK	0	VDD_3V3_LOGIC	eCSPI1 clock
X1A23	X_ECSP11_MOSI	I/O	VDD_3V3_LOGIC	eCSPI1 master output/slave input
X1A24	X_ECSP11_SS0	0	VDD_3V3_LOGIC	eCSPI1 chip select 0 ²²
X1B25	X_ECSP11_MISO	I/O	VDD_3V3_LOGIC	eCSPI1 master input/slave output
X1A43	X_ECSP12_MISO	I/O	VDD_3V3_LOGIC	eCSPI2 master input/slave output
X1A44	X_ECSP12_SS1	0	VDD_3V3_LOGIC	eCSPI2 chip select 1 ²²
X1A45	X_ECSP12_SS0	0	VDD_3V3_LOGIC	eCSPI2 chip select 0
X1B45	X_ECSP12_SCLK	0	VDD_3V3_LOGIC	eCSPI2 clock ²²
X1B46	X_ECSP12_RDY	I	VDD_3V3_LOGIC	eCSPI2 data ready
X1B47	X_ECSP12_MOSI	I/O	VDD_3V3_LOGIC	eCSPI2 master output/slave input

Table 17: SPI Interface Signal Location

Note:

When using the eCSPI1 interface it must be considered that the on-board SPI Flash is connected to this interface, too. The SPI Flash is accessed through SS1 of module eCSPI1 ([section 7.5](#)).

²²: Special care must be taken not to override the device configuration when using this pin as input ([section 6.2](#)).

9.6 I²C Interface

The Inter-Integrated Circuit (I²C) interface is a two-wire, bidirectional serial bus that provides a simple and efficient method for data exchange among devices. The i.MX 6 contains three identical and independent multimaster fast-mode I²C modules. The interface of the first module (I2C1) is available on the phyCORE-Connector.

Note:

To ensure the proper functioning of the I²C interface external pull resistors matching the load at the interface must be connected. There are no pull up resistors mounted on the module.

The following table lists the I²C ports on the phyCORE-Connector.

Pin #	Signal	ST	Voltage Domain	Description
B23	X_I2C1_SCL	OC_BI	VDD_3V3_LOGIC	I2C1 clock
B24	X_I2C1_SDA	OC_BI	VDD_3V3_LOGIC	I2C1 data

Table 18: I²C Interface Signal Location

The third I²C module (I2C3) connects to the on-board EEPROM ([section 7.4](#)) and to the PMIC at U16 ([section 4.2](#)).

9.7 I²S Audio Interface (SSI)

The Synchronous Serial Interface (SSI) of the phyCORE-i.MX 6 is a full-duplex, serial interface that allows to communicate with a variety of serial devices, such as standard codecs, digital signal processors (DSPs), microprocessors, peripherals, and popular industry audio codecs that implement the inter-IC sound bus standard (I²S) and Intel AC'97 standard. The i.MX 6 provides three instances of the SSI module. On the phyCORE-i.MX 6 SSI is brought out to the phyCORE-Connector through port 5 of the i.MX 6's Digital Audio Multiplexer (AUDMUX5).

The main purpose of this interface is to connect to an external codec, such as I²S. The AUDMUX port is intend to be used in synchronous mode (4-wire interface). Hence, the receive data timing is determined by TXC and TXFS. The four signals extending from the i.MX 6 SSI module to the phyCORE-Connector are RXD, TXC, TXFS and TXD.

Pin #	Signal	ST	Voltage Domain	Description
X1D52	X_AUD5_RXD	I/O	VDD_3V3_LOGIC	AUD5 receive data
X1D53	X_AUD5_TXC	I/O	VDD_3V3_LOGIC	AUD5 transmit clock
X1D54	X_AUD5_TXFS	I/O	VDD_3V3_LOGIC	AUD5 frame sync
X1D56	X_AUD5_TXD	I/O	VDD_3V3_LOGIC	AUD5 transmit data

Table 19: I²S Interface Signal Location

9.8 CAN Interface

The CAN interface of the phyCORE-i.MX 6 is connected to the first FlexCAN module (FlexCAN1) of the i.MX 6 which is a full implementation of the CAN protocol specification Version 2.0B. It supports standard and extended message frames and programmable bit rates of up to 1 Mb/s.

The following table shows the position of the signals on the phyCORE-Connector.

Pin #	Signal	ST	Voltage Domain	Description
X1C57	X_FLEXCAN1_TX	O	VDD_3V3_LOGIC	FLEXCAN 1 transmit
X1D57	X_FLEXCAN1_RX	I	VDD_3V3_LOGIC	FLEXCAN 1 receive

Table 20: CAN Interface Signal Location

9.9 SATA Interface

The SATA II interface of the phyCORE-i.MX 6 is a high-speed serialized ATA data link interface compliant with SATA Revision 3.0 (physical layer complies with SATA Revision 2.5) which supports data rates of up to 3.0 Gbit/s. The interface includes an internal DMA engine, command layer, transport layer, link layer and the physical layer. The interface itself supports only one SATA device.

The phyCORE-i.MX 6 provides an SATA II Interface at the following pins of the phyCORE-Connector:

Pin #	Signal	ST	Voltage Domain	Description
X1C8	X_SATA_TXP	LVDS_0	i.MX6 internal	SATA PHY transmit lane+
X1C9	X_SATA_TXN	LVDS_0	i.MX6 internal	SATA PHY transmit lane-
X1D8	X_SATA_RXP	LVDS_I	i.MX 6 internal	SATA PHY receive lane+
X1D9	X_SATA_RXN	LVDS_I	i.MX 6 internal	SATA PHY receive lane-

Table 21: SATA Interface Signal Location

As the signals extend directly from the i.MX 6's SATA PHY a standard SATA connector is all that is needed to interface the phyCORE-i.MX 6's SATA functionality.

9.10 PCI Express Interface

The 1-lane PCI Express interface of the phyCORE-i.MX 6 provides PCIe Gen. 2.0 functionality which supports 5 Gbit/s operation. Furthermore the interface is fully backwards compatible to the 2.5 Gbit/s Gen. 1.1 specification. Additional control signals which might be required (e.g. “present” and “wake”) can be implemented with GPIOs. Please refer to the schematic of a suitable Phytex carrier board (e.g. phyBOARD-Mira i.MX 6) for a circuit example.

[Table 22](#) shows the position of the PCIe signals on the phyCORE-Connector X1.

Pin #	Signal	ST	Voltage Domain	Description
X1C11	X_PCIE0_CLK+	PCIe_0	i.MX 6 internal	PCIe clock lane+
X1C12	X_PCIE0_CLK-	PCIe_0	i.MX 6 internal	PCIe clock lane-
X1C13	X_PCIE_RXP	PCIe_I	i.MX 6 internal	PCIe receive lane+
X1C14	X_PCIE_RXN	PCIe_I	i.MX 6 internal	PCIe receive lane-
X1D10	X_PCIE_TXP	PCIe_0	i.MX 6 internal	PCIe transmit lane+
X1D11	X_PCIE_TXN	PCIe_0	i.MX 6 internal	PCIe transmit lane-

Table 22: *PCIe Interface Signal Location*

10 General Purpose I/Os

Table 23 lists all pins not used by any other of the interfaces described explicitly in this manual and which therefore can be used as GPIO without harming other features of the phyCORE-i.MX 6.

Pin #	Signal	ST	Voltage Domain	Description
X1A25	X_EIM_DA13	I/O	VDD_3V3_LOGIC	EIM address/data 13; GPIO3_13
X1A42	X_EIM_BCLK	0	VDD_3V3_LOGIC	EIM burst block; GPIO6_31
X1B26	X_EIM_DA14	I/O	VDD_3V3_LOGIC	EIM address/data 14; GPIO3_14
X1B27	X_EIM_DA15	I/O	VDD_3V3_LOGIC	EIM address/data 15; GPIO3_15
X1B44	X_EIM_EB1	0	VDD_3V3_LOGIC	EIM enable byte 1; GPIO2_29
X1C16	X_SPDIF_OUT	0	VDD_3V3_LOGIC	SPDIF output; GPIO7_12
X1C17	X_PWM1_OUT	0	VDD_3V3_LOGIC	PWM1 output; GPIO1_09
X1D13	X_KEY_COL2	I	VDD_3V3_LOGIC	Keypad column 2; GPIO4_10

Table 23: Location of GPIO Pins

Beside these pins, most of the i.MX 6 signals which are connected directly to the module connector can be configured to act as GPIO, due to the multiplexing functionality of most controller pins.

Caution!

Depending on the boot mode, signals at pins X1A25 (EIM_DA13), X1B26 (EIM_DA14), X1B27 (EIM_DA15) and X1B44 (EIM_EB1) are latched during boot to determine the device configuration (*section 5*). Because of that special care must be taken not to override the device configuration when using these pins as input. To avoid this danger, the eFUSES can be used.

11 User LED

The phyCORE-i.MX 6 provides one green user LED (D1) on board. It can be controlled by setting GPIO1_04 to the desired output level. A high-level turns the LED on, a low-level turns it off.

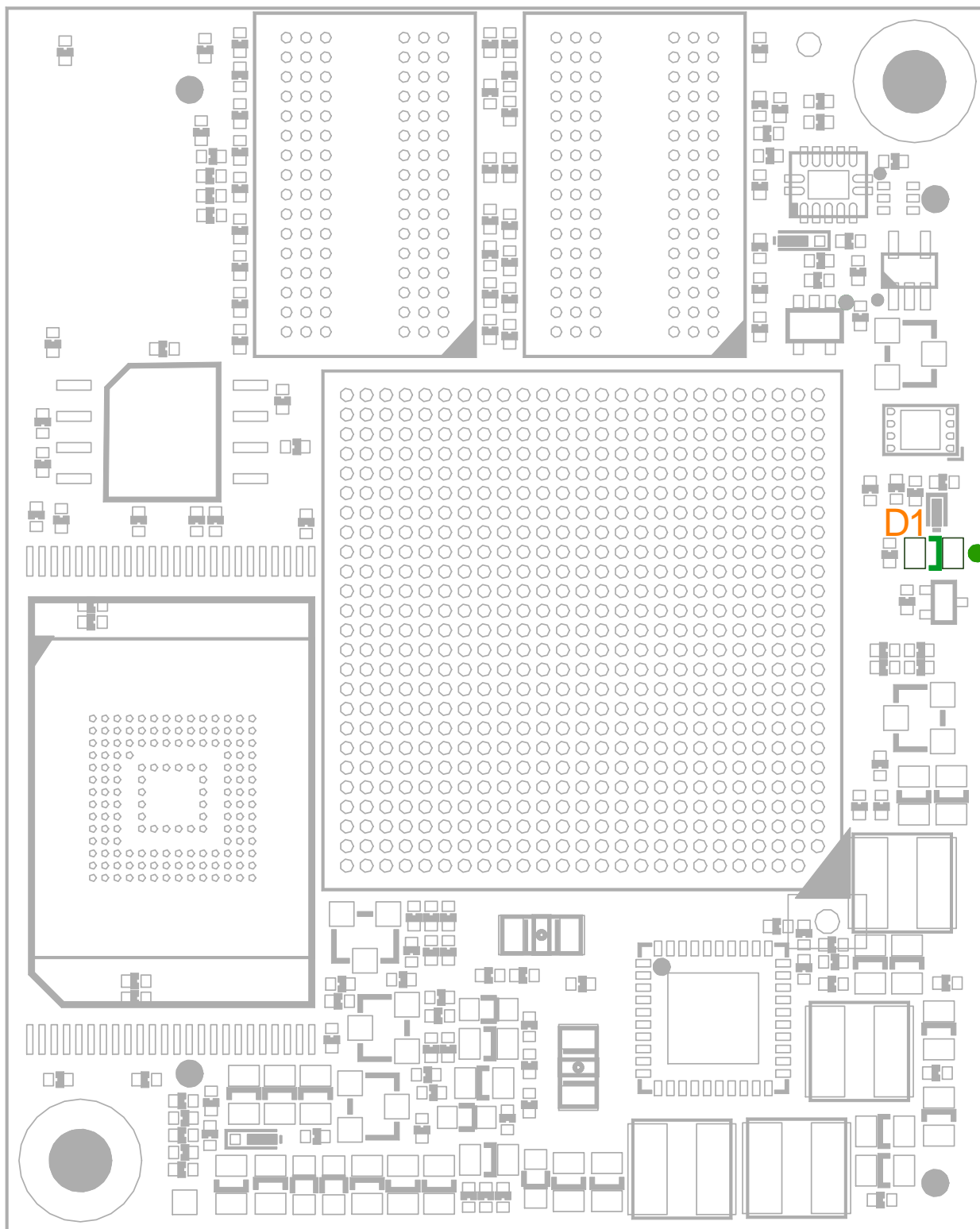

Figure 9: User LED Location (top view)

12 Debug Interface

The phyCORE-i.MX 6 is equipped with a JTAG interface for downloading program code into the external flash, internal controller RAM or for debugging programs currently executing.

[Table 24](#) shows the location of the JTAG pins on the phyCORE-Connector X1.

Pin #	Signal	ST	Voltage Domain	Description
X1C28	X_JTAG_TMS	I	VDD_3V3_LOGIC	JTAG TMS
X1C29	X_JTAG_TDO	O	VDD_3V3_LOGIC	JTAG TDO
X1D23	X_JTAG_TCK	I	VDD_3V3_LOGIC	JTAG clock input
X1D25	X_JTAG_TRSTB	I	VDD_3V3_LOGIC	JTAG reset input (low active)
X1D26	X_JTAG_TDI	I	VDD_3V3_LOGIC	JTAG TDI

Table 24: Debug Interface Signal Location at phyCORE-Connector X1

13 Display Interfaces

13.1 Parallel Display Interface

The signals from the LCD interface of the i.MX 6 are brought out at the phyCORE-Connector X1. Thus an LCD interface with up to 24-bit bus width can be connected directly to the phyCORE-i.MX 6. The table below shows the location of the applicable interface signals.

Pin #	Signal	ST	Voltage Domain	Description
X1A47	X_LCD_DATA22	0	VDD_3V3_LOGIC	DISP0 data 22
X1A48	X_LCD_DATA21	0	VDD_3V3_LOGIC	DISP0 data 21
X1A49	X_LCD_DATA19	0	VDD_3V3_LOGIC	DISP0 data 19
X1A50	X_LCD_DATA16	0	VDD_3V3_LOGIC	DISP0 data 16
X1A52	X_LCD_DATA14	0	VDD_3V3_LOGIC	DISP0 data 14
X1A53	X_LCD_DATA13	0	VDD_3V3_LOGIC	DISP0 data 13
X1A54	X_LCD_DATA11	0	VDD_3V3_LOGIC	DISP0 data 11
X1A55	X_LCD_DATA08	0	VDD_3V3_LOGIC	DISP0 data 8
X1A57	X_LCD_DATA06	0	VDD_3V3_LOGIC	DISP0 data 6
X1A58	X_LCD_DATA05	0	VDD_3V3_LOGIC	DISP0 data 5
X1A59	X_LCD_DATA03	0	VDD_3V3_LOGIC	DISP0 data 3
X1A60	X_LCD_DATA00	0	VDD_3V3_LOGIC	DISP0 data 0
X1A62	X_LCD_ENABLE	0	VDD_3V3_LOGIC	DISP0 enable
X1A63	X_LCD_HSYNC	0	VDD_3V3_LOGIC	DISP0 horizontal sync
X1A64	X_LCD_RESET	0	VDD_3V3_LOGIC	DISP0 reset
X1B49	X_LCD_DATA23	0	VDD_3V3_LOGIC	DISP0 data 23
X1B50	X_LCD_DATA20	0	VDD_3V3_LOGIC	DISP0 data 20
X1B51	X_LCD_DATA18	0	VDD_3V3_LOGIC	DISP0 data 18
X1B52	X_LCD_DATA17	0	VDD_3V3_LOGIC	DISP0 data 17
X1B54	X_LCD_DATA15	0	VDD_3V3_LOGIC	DISP0 data 15
X1B55	X_LCD_DATA12	0	VDD_3V3_LOGIC	DISP0 data 12
X1B56	X_LCD_DATA10	0	VDD_3V3_LOGIC	DISP0 data 10
X1B57	X_LCD_DATA09	0	VDD_3V3_LOGIC	DISP0 data 9
X1B59	X_LCD_DATA07	0	VDD_3V3_LOGIC	DISP0 data 7
X1B60	X_LCD_DATA04	0	VDD_3V3_LOGIC	DISP0 data 4
X1B61	X_LCD_DATA02	0	VDD_3V3_LOGIC	DISP0 data 2
X1B62	X_LCD_DATA01	0	VDD_3V3_LOGIC	DISP0 data 1
X1B64	X_LCD_CLK	0	VDD_3V3_LOGIC	DISP0 clock
X1B65	X_LCD_VSYNC	0	VDD_3V3_LOGIC	DISP0 vertical sync

Table 25: Parallel Display Interface Signal Location

13.2 LVDS Display Interface

The LVDS-Signals from both channels of the on-chip LVDS Display Bridge (LDB) on the i.MX 6 are brought out at phyCORE-Connector X1. Thus up to two LVDS-Displays can be connected directly to the phyCORE-i.MX 6. The location of the applicable interface signals can be found in the table below.

Pin #	Signal	ST	Voltage Domain	Description
X1C59	X_LVDS0_TX1+	LVDS_0	i.MX 6 internal	LVDS0 data 1+
X1C60	X_LVDS0_TX1-	LVDS_0	i.MX 6 internal	LVDS0 data 1-
X1C61	X_LVDS0_TX0+	LVDS_0	i.MX 6 internal	LVDS0 data 0+
X1C62	X_LVDS0_TX0-	LVDS_0	i.MX 6 internal	LVDS0 data 0-
X1C64	X_LVDS0_TX3+	LVDS_0	i.MX 6 internal	LVDS0 data 3+
X1C65	X_LVDS0_TX3-	LVDS_0	i.MX 6 internal	LVDS0 data 3-
X1D58	X_LVDS0_CLK+	LVDS_0	i.MX 6 internal	LVDS0 clock+
X1D59	X_LVDS0_CLK-	LVDS_0	i.MX 6 internal	LVDS0 clock-
X1D60	X_LVDS0_TX2+	LVDS_0	i.MX 6 internal	LVDS0 data 2+
X1D61	X_LVDS0_TX2-	LVDS_0	i.MX 6 internal	LVDS0 data 2-
X1C66	X_LVDS1_CLK+	LVDS_0	i.MX 6 internal	LVDS1 clock+
X1C67	X_LVDS1_CLK-	LVDS_0	i.MX 6 internal	LVDS1 clock-
X1C69	X_LVDS1_TX0+	LVDS_0	i.MX 6 internal	LVDS1 data 0+
X1C70	X_LVDS1_TX0-	LVDS_0	i.MX 6 internal	LVDS1 data 0-
X1D63	X_LVDS1_TX2+	LVDS_0	i.MX 6 internal	LVDS1 data 2+
X1D64	X_LVDS1_TX2-	LVDS_0	i.MX 6 internal	LVDS1 data 2-
X1D65	X_LVDS1_TX1+	LVDS_0	i.MX 6 internal	LVDS1 data 1+
X1D66	X_LVDS1_TX1-	LVDS_0	i.MX 6 internal	LVDS1 data 1-
X1D68	X_LVDS1_TX3+	LVDS_0	i.MX 6 internal	LVDS1 data 3+
X1D69	X_LVDS1_TX3-	LVDS_0	i.MX 6 internal	LVDS1 data 3-

Table 26: LVDS Display Interface Signal Location

13.3 Supplementary Signals

Pin #	Signal	ST	Voltage Domain	Description
X1C17	X_PWM1_OUT	0	VDD_3V3_LOGIC	PWM1 output (e.g. to control the brightness)

Table 27: Supplementary Signals to support the Display Connectivity

14 High-Definition Multimedia Interface (HDMI)

The High-Definition Multimedia Interface (HDMI) of the phyCORE-i.MX 6 is compliant to HDMI 1.4 and DVI 1.0. It supports a maximum pixel clock of up to 340 MHz for up to 720p at 100 Hz and 720i at 200 Hz, or 1080p at 60 Hz and 1080i/720i at 120 Hz HDTV display resolutions, and a graphic display resolution of up to 2048x1536 (QXGA). Please refer to the *i.MX 6 Reference Manual* for more information.

The following table shows the location of the HDMI signals on the phyCORE-Connector.

Pin #	Signal	ST	Voltage Domain	Description
X1C38	X_HDMI_CEC	I/O	VDD_3V3_LOGIC	HDMI CEC
X1C39	X_HDMI_CLKP	TDMS_0	i.MX 6 internal	HDMI clock+
X1C40	X_HDMI_CLKM	TDMS_0	i.MX 6 internal	HDMI clock-
X1C41	X_HDMI_D1P	TDMS_0	i.MX 6 internal	HDMI data1+
X1C42	X_HDMI_D1M	TDMS_0	i.MX 6 internal	HDMI data1-
X1C44	X_HDMI_DDC_SDA	I/O	VDD_3V3_LOGIC	HDMI DDC data
X1D33	X_HDMI_D2P	TDMS_0	i.MX 6 internal	HDMI data2+
X1D34	X_HDMI_D2M	TDMS_0	i.MX 6 internal	HDMI data2-
X1D35	X_HDMI_HPD	I	VDD_3V3_LOGIC	HDMI hot plug detect
X1D37	X_HDMI_D0P	TDMS_0	i.MX 6 internal	HDMI data0+
X1D38	X_HDMI_D0M	TDMS_0	i.MX 6 internal	HDMI data0-
X1D39	X_HDMI_DDC_SCL	I/O	VDD_3V3_LOGIC	HDMI DDC clock

Table 28: HDMI Interface Signal Location

As the signals extend directly from the i.MX 6's HDMI PHY a standard HDMI connector, a 5 V level shifter for the DDC and the CEC signals and an optional ESD circuit protection device is all that is needed to interface the phyCORE-i.MX 6's HDMI functionality.

15 Camera Interfaces

The phyCORE-i.MX 6 SOM offers various interfaces to connect digital cameras. Up to two parallel camera interfaces (IPU1_CSI0 and IPU2_CSI1²³) as well as the interface to the MIPI/CSI-2 Host Controller are supported and brought out in different ways. All signals (including control signals and an I²C interface) to use the camera interfaces according to Phytect's phyCAM-S+, or phyCAM-P standard are available at the phyCORE-Connector.

The i.MX 6 (Solo), and i.MX 6 (DualLite) microcontrollers are equipped with one parallel camera port (IPU1_CSI0) and one image processing units (version 3H) (IPU #1) to process the signals from the parallel, or the MIPI camera interface (*Figure 10*). The i.MX 6D (dual core), and i.MX 6Q (quad core) provide an additional parallel camera port (IPU2_CSI1) and a second image processing unit (IPU #2²³) (*Figure 11*). The second, independent image processing unit of the i.MX 6D (dual core), and the i.MX 6Q (quad core) allows to operate two cameras at the same time.

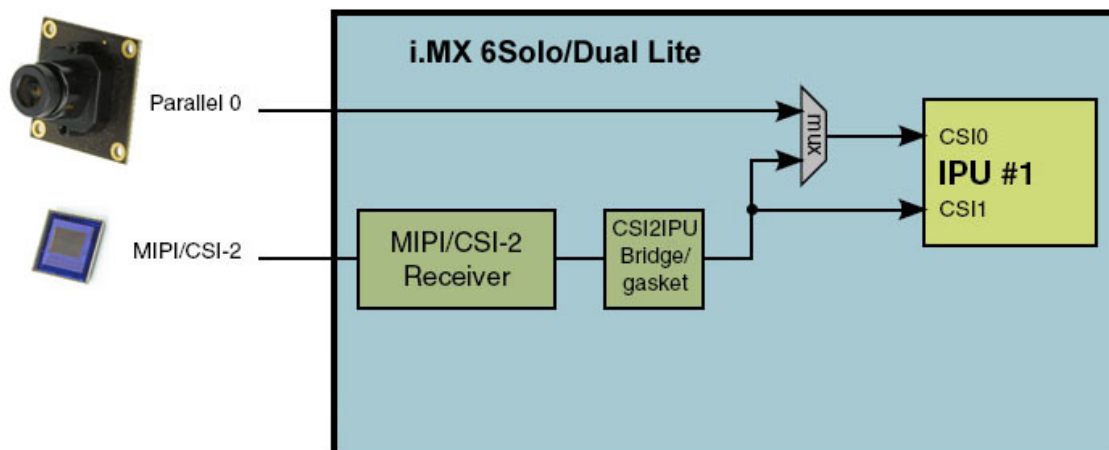

Figure 10: Camera Connectivity of the i.MX 6 (Solo/DualLite)

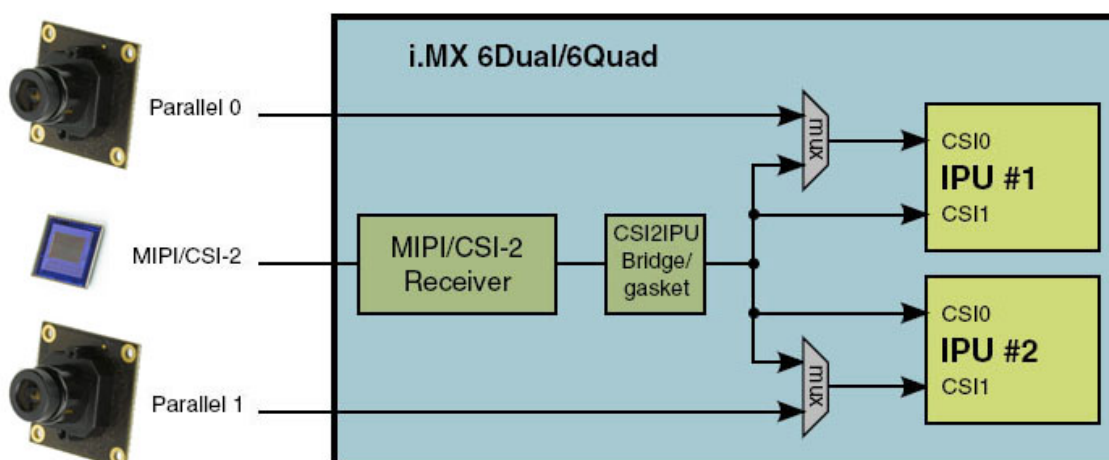

Figure 11: Camera Connectivity of the i.MX 6 (Dual Core/Quad Core)

²³: only i.MX 6 with Dual- or Quad core. i.MX 6 with Solo-, or DualLite core provide only one parallel camera interface and one IPU.

On the phyCORE-i.MX 6 SOM camera port IPU1_CSI0 is brought out as parallel interfaces (Parallel 0) with 16 data bits, HSYNC, VSYNC and PIXCLK. Camera port IPU2_CSI1 is also available as parallel interfaces (Parallel 1) with 20 data bits, HSYNC, VSYNC and PIXCLK. The MIPI/CSI-2 interface connects to the phyCORE-Connector with 5-lanes (Figure 12)

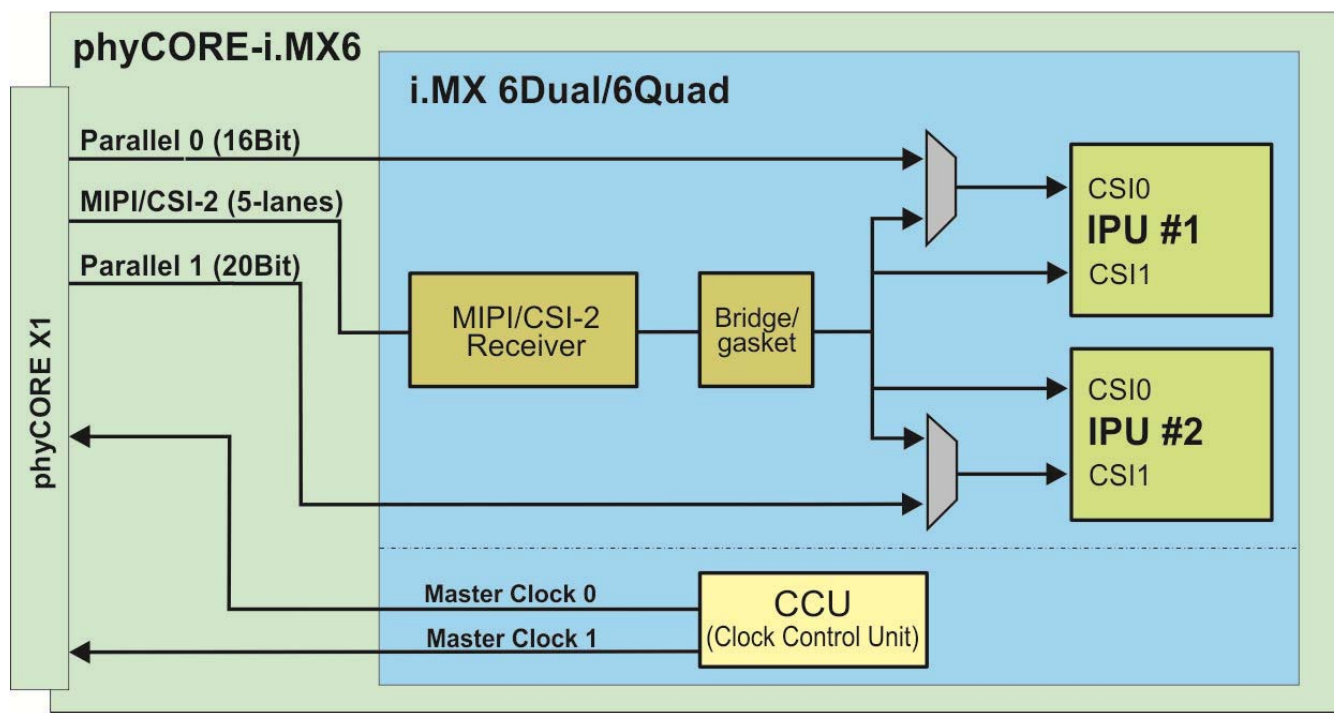

Figure 12: Camera Interfaces at the phyCORE-Connector (Parallel 0(CSI0 of IPU#1), Parallel 1(CSI1 of IPU#2), and MIPI/CSI-2)

The camera interfaces of the phyCORE-i.MX 6 include all signals and are prepared to be used as phyCAM-S(+), phyCAM-P, or MIPI/CSI-2 interface on an appropriate carrier board. Please refer to [section 15.4](#) for more information on how to use the camera interfaces on a carrier board with different interface options.

15.1 Parallel 0 Camera Interface (CSIO of IPU#1)

The camera interface Parallel 0 (CSIO of IPU#1) is available at the phyCORE-Connector with 16 data bits, HSYNC, VSYNC and PIXCLK.

The following table shows the location of the Parallel 0 (CSIO of IPU#1) camera signals at the phyCORE-Connector.

Pin #	Signal	ST	Voltage Domain	Description
X1D40	X_CSIO_DAT19	I	VDD_3V3_LOGIC	IPU1_CSIO data 19
X1C45	X_CSIO_DAT18	I	VDD_3V3_LOGIC	IPU1_CSIO data 18
X1D41	X_CSIO_DAT17	I	VDD_3V3_LOGIC	IPU1_CSIO data 17
X1C46	X_CSIO_DAT16	I	VDD_3V3_LOGIC	IPU1_CSIO data 16
X1D43	X_CSIO_DAT15	I	VDD_3V3_LOGIC	IPU1_CSIO data 15
X1C47	X_CSIO_DAT14	I	VDD_3V3_LOGIC	IPU1_CSIO data 14
X1D44	X_CSIO_DAT13	I	VDD_3V3_LOGIC	IPU1_CSIO data 13
X1C49	X_CSIO_DAT12	I	VDD_3V3_LOGIC	IPU1_CSIO data 12
X1D45	X_CSIO_DAT11	I	VDD_3V3_LOGIC	IPU1_CSIO data 11
X1C50	X_CSIO_DAT10	I	VDD_3V3_LOGIC	IPU1_CSIO data 10
X1D46	X_CSIO_DAT9	I	VDD_3V3_LOGIC	IPU1_CSIO data 9
X1C51	X_CSIO_DAT8	I	VDD_3V3_LOGIC	IPU1_CSIO data 8
X1D47	X_CSIO_DAT7	I	VDD_3V3_LOGIC	IPU1_CSIO data 7
X1C52	X_CSIO_DAT6	I	VDD_3V3_LOGIC	IPU1_CSIO data 6
X1C53	X_CSIO_DAT5	I	VDD_3V3_LOGIC	IPU1_CSIO data 5
X1C55	X_CSIO_DAT4	I	VDD_3V3_LOGIC	IPU1_CSIO data 4
X1C56	X_CSIO_PIXCLK	O	VDD_3V3_LOGIC	IPU1_CSIO pixel clock
X1D48	X_CSIO_VSYNC	I	VDD_3V3_LOGIC	IPU1_CSIO vertical sync
X1D51	X_CSIO_HSYNC	I	VDD_3V3_LOGIC	IPU1_CSIO horizontal sync
X1D16	X_CCM_CLKO1	O	VDD_3V3_LOGIC	CCM clock output 1 (Camera0 MCLK)
Signals that can be optionally used with the camera ports				
X1B23	X_I2C1_SCL	OC_BI	VDD_3V3_LOGIC	I2C1 clock
X1B24	X_I2C1_SDA	OC_BI	VDD_3V3_LOGIC	I2C1 data
X1D50	X_CSIO_DATA_EN	O	VDD_3V3_LOGIC	IPU1_CSIO data enable ²⁴
X1A38	X_CSI1_DATA00	I	VDD_3V3_LOGIC	CSI1 data 0 (GPIO3_09) ^{24, 25}

Table 29: Camera Interface Parallel 0 (IPU1_CSIO) Signal Location

Using the phyCORE's camera interface Parallel 0, together with an I²C bus facilitates easy implementation of a CMOS camera interface, e.g. a phyCAM-P or a phyCAM-S+ interface, on a custom carrier board ([section 15.4](#)).

²⁴: Recommended to implement special control features for the camera interface circuitry on the carrier board (e.g. enabling/disabling of the interface, switching between phyCAM-P and phyCAM-S, etc.). Please refer to L-748 or appropriate Phytect CB designs as reference.

15.2 Parallel 1 Camera Interface (CSI1 of IPU#2)

The camera interface Parallel 1 (CSI1 of IPU#2) is available at the phyCORE-Connector with 20 data bits, HSYNC, VSYNC and PIXCLK.

The following table shows the location of the Parallel 1 (CSI1 of IPU#2) camera signals at the phyCORE-Connector.

Pin #	Signal	ST	Voltage Domain	Description
X1B29	X_CSI1_DATA19	I	VDD_3V3_LOGIC	IPU2_CSI1 data 19 ²⁵
X1B30	X_CSI1_DATA18	I	VDD_3V3_LOGIC	IPU2_CSI1 data 18 ²⁵
X1B31	X_CSI1_DATA17	I	VDD_3V3_LOGIC	IPU2_CSI1 data 17 ²⁵
X1B32	X_CSI1_DATA16	I	VDD_3V3_LOGIC	IPU2_CSI1 data 16 ²⁵
X1B34	X_CSI1_DATA15	I	VDD_3V3_LOGIC	IPU2_CSI1 data 15 ²⁵
X1B35	X_CSI1_DATA14	I	VDD_3V3_LOGIC	IPU2_CSI1 data 14 ²⁵
X1B37	X_CSI1_DATA13	I	VDD_3V3_LOGIC	IPU2_CSI1 data 13 ²⁵
X1A27	X_CSI1_DATA12	I	VDD_3V3_LOGIC	IPU2_CSI1 data 12 ²⁵
X1A28	X_CSI1_DATA11	I	VDD_3V3_LOGIC	IPU2_CSI1 data 11 ²⁵
X1A29	X_CSI1_DATA10	I	VDD_3V3_LOGIC	IPU2_CSI1 data 10
X1A30	X_CSI1_DATA09	I	VDD_3V3_LOGIC	IPU2_CSI1 data 9 ²⁵
X1A32	X_CSI1_DATA08	I	VDD_3V3_LOGIC	IPU2_CSI1 data 8 ²⁵
X1B39	X_CSI1_DATA07	I	VDD_3V3_LOGIC	IPU2_CSI1 data 7 ²⁵
X1B40	X_CSI1_DATA06	I	VDD_3V3_LOGIC	IPU2_CSI1 data 6 ²⁵
X1B41	X_CSI1_DATA05	I	VDD_3V3_LOGIC	IPU2_CSI1 data 5 ²⁵
X1B42	X_CSI1_DATA04	I	VDD_3V3_LOGIC	IPU2_CSI1 data 4 ²⁵
X1A33	X_CSI1_DATA03	I	VDD_3V3_LOGIC	IPU2_CSI1 data 3 ²⁵
X1A34	X_CSI1_DATA02	I	VDD_3V3_LOGIC	IPU2_CSI1 data 2 ²⁵
X1A37	X_CSI1_DATA01	I	VDD_3V3_LOGIC	IPU2_CSI1 data 1 ²⁵
X1A38	X_CSI1_DATA00	I	VDD_3V3_LOGIC	IPU2_CSI1 data 0 ²⁵
X1A39	X_CSI1_VSYNC	I	VDD_3V3_LOGIC	IPU2_CSI1 vertical sync ²⁵
X1A40	X_CSI1_HSYNC	I	VDD_3V3_LOGIC	IPU2_CSI1 horizontal sync ²⁵
X1B36	X_CSI1_PIXCLK	O	VDD_3V3_LOGIC	IPU2_CSI1 pixel clock ²⁵
X1C22	X_CCM_CLK02	O	VDD_3V3_LOGIC	CCM clock output 2 (Camera2 MCLK)
Signals that can be optionally used with the camera ports				
X1B23	X_I2C1_SCL	OC_BI	VDD_3V3_LOGIC	I2C1 clock
X1B24	X_I2C1_SDA	OC_BI	VDD_3V3_LOGIC	I2C1 data
X1A35	X_CSI1_DATA_EN	O	VDD_3V3_LOGIC	IPU2_CSI1 data enable ^{25, 26}
X1A37	X_CSI1_DATA01	I	VDD_3V3_LOGIC	IPU2_CSI1 data 1 (GPIO3_08) ^{25,26}

Table 30: Camera Interface Parallel 1 (IPU2_CSI1) Signal Location

²⁵: Special care must be taken not to override the device configuration when using this pin as input ([section 6.2](#)).

²⁶: Recommended to implement special control features for the camera interface circuitry on the carrier board (e.g. enabling/disabling of the interface, switching between phyCAM-P and phyCAM-S, etc.). Please refer to L-748 or appropriate Phytec CB designs as reference.

Using the phyCORE's camera interface Parallel 1, together with an I²C bus facilitates easy implementation of a CMOS camera interface, e.g. a phyCAM-P or a phyCAM-S+ interface, on a custom carrier board ([section 15.4](#)).

15.3 MIPI/CSI-2 Camera Interface

The MIPI/CSI-2 camera interface of the i.MX 6 extends to the phyCORE-Connector X1 with 4 data lanes and one clock lane.

Note:

It is not possible to use the MIPI/CSI-2 interface and the IPU1_CSI0 or IPU2_CSI1 interface at the same time.

The following table shows the location of the signals.

Pin #	Signal	ST	Voltage Domain	Description
X1C30	X_CSI_D0P	CSI2_I	i.MX 6 internal	MIPI/CSI data0+
X1C31	X_CSI_D0M	CSI2_I	i.MX 6 internal	MIPI/CSI data0-
X1D27	X_CSI_D1P	CSI2_I	i.MX 6 internal	MIPI/CSI data1+
X1D28	X_CSI_D1M	CSI2_I	i.MX 6 internal	MIPI/CSI data1-
X1C33	X_CSI_D2P	CSI2_I	i.MX 6 internal	MIPI/CSI data2+
X1C34	X_CSI_D2M	CSI2_I	i.MX 6 internal	MIPI/CSI data2-
X1D29	X_CSI_D3P	CSI2_I	i.MX 6 internal	MIPI/CSI data3+
X1D30	X_CSI_D3M	CSI2_I	i.MX 6 internal	MIPI/CSI data3-
X1C35	X_CSI_CLK0P	CSI2_I	i.MX 6 internal	MIPI/CSI clock+
X1C36	X_CSI_CLK0M	CSI2_I	i.MX 6 internal	MIPI/CSI clock-
Signals that can be optionally used with the camera ports				
X1B23	X_I2C1_SCL	OC_BI	VDD_3V3_LOGIC	I2C1 clock
X1B24	X_I2C1_SDA	OC_BI	VDD_3V3_LOGIC	I2C1 data
X1D16	X_CCM_CLK01	0	VDD_3V3_LOGIC	CCM clock output 1 (Camera0 MCLK)

Table 31: Camera Interface MIPI/CSI-2 Signal Location

Use of the I²C bus and the camera clock signal allows to directly connect a MIPI/CSI-2 camera module.

15.4 Utilizing the Camera Interfaces on a Carrier Board

On Phytec carrier boards the interfaces are used directly as parallel interface according to the phyCAM-P standard (Figure 13) and/or by converting the signals with an LVDS deserializer as serial interface following the phyCAM-S+ standard (Figure 14), or as MIPI/CSI-2 interface.

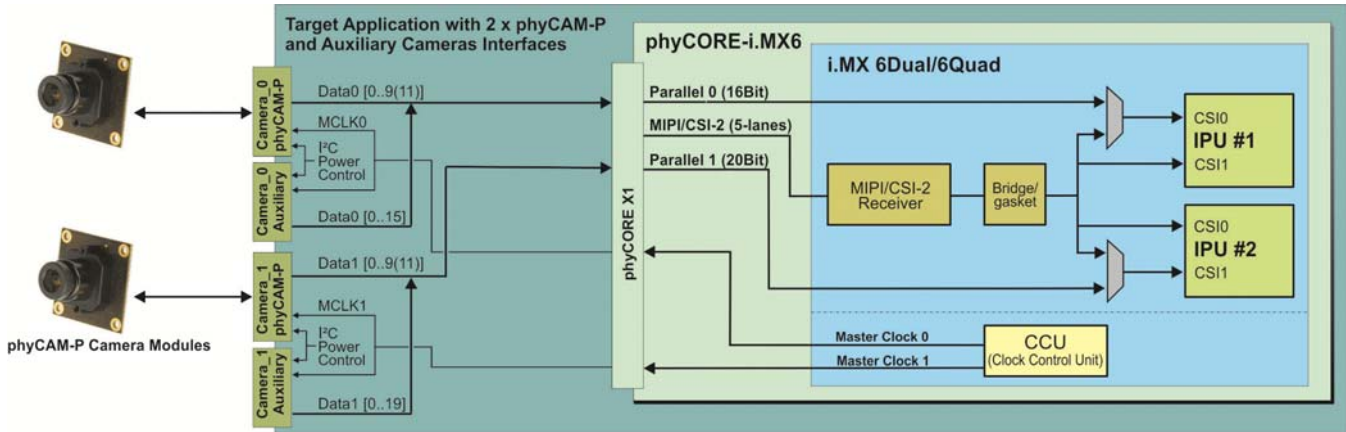

Figure 13: Use of Parallel 0 (CSI0 of IPU#1) and Parallel 1 (CSI1 of IPU#2) as phyCAM-P interface

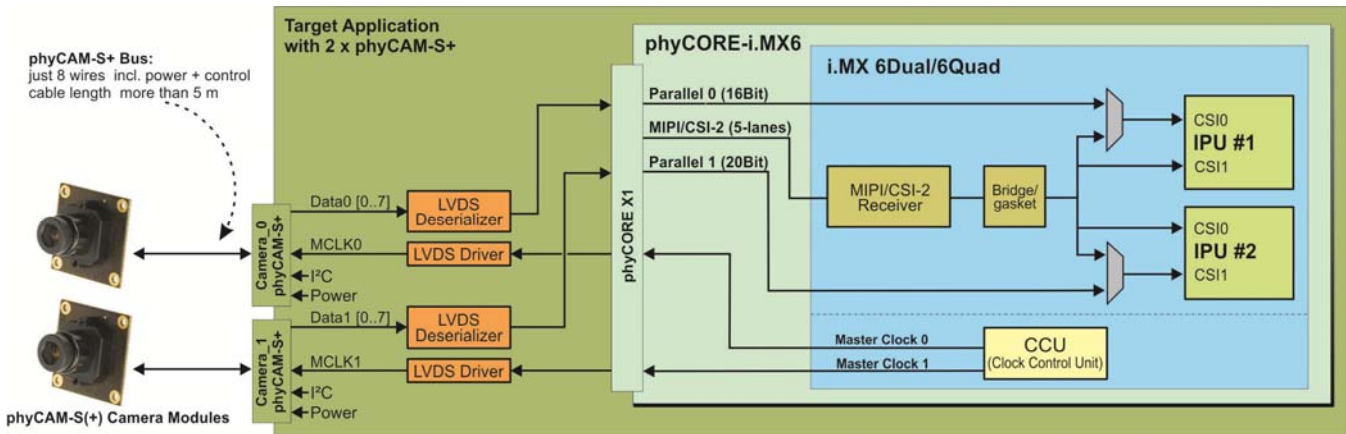

Figure 14: Use of Parallel 0 (CSI0 of IPU#1) and Parallel 1 (CSI1 of IPU#2) as phyCAM-S+ interface

More information on the Phytec camera interface standards phyCAM-P and phyCAM-S+ and how to implement them on a custom carrier board can be found in the corresponding manual L-748. The schematics of the phyBOARD-Mira i.MX 6 on which camera interface Parallel 0 is brought out as phyCAM-S+ interface (LVDS) can also serve as reference design.

16 Tamper Detection

The phyCORE-i.MX 6 supports the tamper detection feature of the i.MX 6. With the tamper detection feature it is possible to recognize when the device encounters unauthorized opening, or tampering.

For this purpose, the i.MX 6's Tamper Detection signal is available at pin X1D70 of the phyCORE-Connector.

When not in use, the Tamper Detection signal is pulled-down internally. In order to implement tamper protection this signal should be connected to a Tamper Detection contact in the application which is normally closed pulling the Tamper Detection signal to the power domain VDD_MX6_SNVS on the phyCORE-i.MX 6 (i.MX 6: VDD_SNVS_IN).

For proper operation of the tamper detection an always-ON power supply (coin cell battery, or memory backup capacitor) must be connected to the VDD_MX6_SNVS power input at pin X1A5 of the phyCORE-Connector.

If the tamper detection feature is enabled by software then opening of the tamper contact can, e.g., result in:

- switching system power ON with a Tamper Detection alarm interrupt asserted (for software reaction) , or
- activating security related hardware (e.g. automatic and immediate erasure of the Zeroizable Master Key and deny access and erase secure memory contents)

Caution:

To use tamper detection ensure the correct configuration of jumpers J3 and J6. J3 must be set to 2+3 to connect a backup voltage source to the i.MX 6 low power domain (SNVS_LP). J6 must be closed at 1+2 to route the TAMPER signal to pin X1D70 of the phyCORE-Connector.

17 Technical Specifications

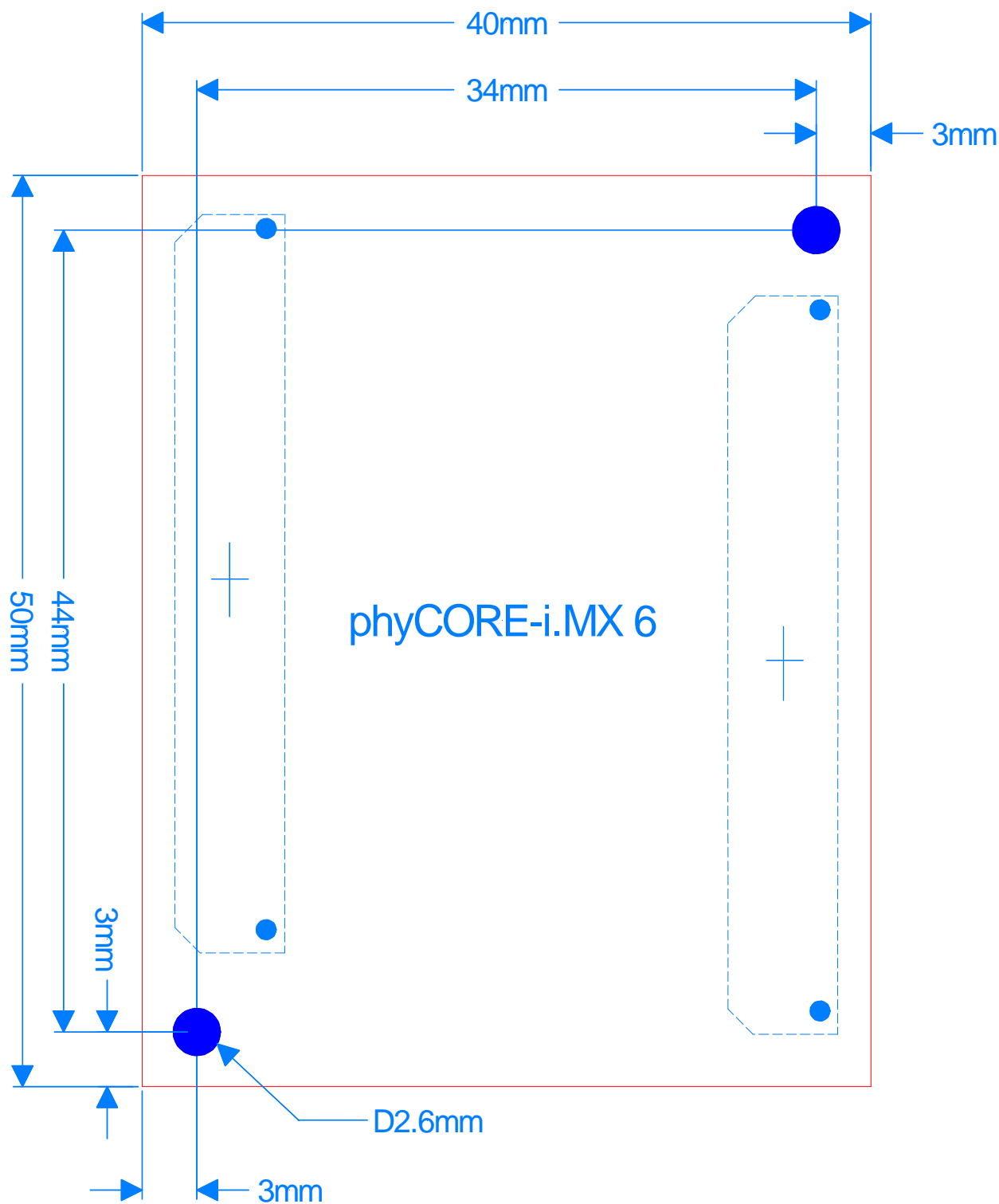

Figure 15: Physical Dimensions (top view)

The physical dimensions of the phyCORE-i.MX 6 are represented in [Figure 15](#). The module's profile is max. 10 mm thick, with a maximum component height of 3.0 mm on the bottom (connector) side of the PCB and approximately 5.0 mm on the top (microcontroller) side. The board itself is approximately 1.4 mm thick.

Note:

To facilitate the integration of the phyCORE-i.MX 6 into your design, the footprint of the phyCORE-i.MX 6 is available for download ([section 18.1](#)).

Additional specifications:

Dimensions:	40 mm x 50 mm
Weight:	approx. 17.4 g ²⁷
Storage temperature:	-40 °C to +125 °C
Operating temperature:	refer to section 17.1
Humidity:	95 % r.F. not condensed
Operating voltage:	VCC 3.3 V +/- 5 %
Power consumption:	Linux prompt only: typical 1.9 W QT Demo: typical 4.1 W 4 Cores full load + QT Demo: typical 6 W Conditions: 1 GB DDR3-SDRAM, 1 GB NAND Flash, Ethernet, Quad core 1 GHz CPU frequency, 20 °C, 3.3 V

Table 32: Technical Specifications

These specifications describe the standard configuration of the phyCORE-i.MX 6 as of the printing of this manual.

²⁷: depending on the configuration of the module

17.1 Product Temperature Grades

Caution!

The right temperature grade of the Module depends very much on the use case. It is mandatory to determine if the use case suits the temperature range of the chosen module (see below). If necessary a heat spreader can be used for temperature compensation

The feasible operating temperature of the SOM highly depends on the use case of your software application. Modern high performance microcontrollers and other active parts as the ones described within this manual are usually rated by qualifications based on tolerable junction or case temperatures. Therefore, making a general statement about maximum or minimum ambient temperature ratings for the described SOM is not possible. However, the above mentioned parts are available still in different temperature qualification levels by the producers. We offer our SOM's in different configurations making use of those temperature qualifications. To indicate which level of temperature qualification is used for active and passive parts of a SOM configuration we have categorized our SOM's in three temperature grades. The table below describes these grades in detail. These grades describe a set of components which in combination add up to a useful set of product options with different temperature grades. This enables us to make use of cost optimizations depending on the required temperature range.

In order to determine the right temperature grade and whether the maximum or minimum qualification levels are met within an application the following conditions must be defined by considering the use case:

- Determined processing load for the given software use case
- Maximum temperature ranges of components (see table below)
- Power consumption resulting from a base load and the calculating power required (in consideration of peak loads as well as time periods for system cool down)
- Surrounding temperatures and existing airflow in case the system is mounted into a housing
- Heat resistance of the heat dissipation paths within the system along with the considered usage of a heat spreader or a heat sink to optimize heat dissipation

Product Temp. Grade	Controller Temp Range (Junction Temp)	RAM (Case Temp)	Others (Ambient)
I	Industrial -40 °C to +105 °C / Automotive -40 °C to +125 °C	Industrial -40 °C to +95 °C	Industrial -40 °C to +85 °C
X	Extended Commercial -20 °C to +105 °C	Industrial -40 °C to +95 °C	Industrial -40 °C to +85 °C
C	Commercial 0 °C to +95 °C	Consumer 0 °C to +95 °C	Consumer 0 °C to +70 °C

Table 33: Product Temperature Grades

17.2 Connectors on the phyCORE-i.MX 6:

Manufacturer	Samtec
Number of pins per contact rows	phyCORE-Connector X1: 140 pins (2 rows of 70 pins each)
Samtec part number (lead free)	BSH-070-01-L-D-A-K-TR (old part#) REF-183456-03

Information on the receptacle sockets that correspond to the connectors populating the underside of the phyCORE—i.MX 6 is provided below.

The given connector height indicates the distance between the two connected PCBs when the module is mounted on the corresponding carrier board. In order to get the exact spacing, the maximum component height (3 mm) on the bottom side of the phyCORE must be subtracted.

Mating Connector

Connector height 5 mm

Manufacturer	Samtec
Number of pins per contact row	140 pins (2 rows of 70 pins each)
Samtec part number (lead free)	BTH-070-01-L-D-A-K-TR (old part#) REF-183457-03
PHYTEC part number (lead free)	VM317

Please refer to the corresponding data sheets and mechanical specifications provided by Samtec (www.samtec.com).

18 Hints for Integrating and Handling the phyCORE-i.MX 6

18.1 Integrating the phyCORE-i.MX 6

Besides this hardware manual much information is available to facilitate the integration of the phyCORE-i.MX 6 into customer applications.

1. the design of the phyBOARD-Mira i.MX 6 can be used as a reference for any customer application
2. many answers to common questions can be found at <http://www.phytec.de/support/knowledge-database/soms-system-on-modules/phycore/phycore-imx-6/>,
or
<http://www.phytec.eu/europe/support/faq/faq-phyCORE-i.MX 6.html>
3. the link "Carrier Board" within the category Dimensional Drawing leads to the layout data as shown in *Figure 16*. It is available in different file formats. Use of this data allows to integrate the phyCORE-i.MX 6 SOM as a single component into your design.
4. different support packages are available to support you in all stages of your embedded development. Please visit <http://www.phytec.de/de/support/support-pakete.html>, or <http://www.phytec.eu/europe/support/support-packages.html>, or contact our sales team for more details.

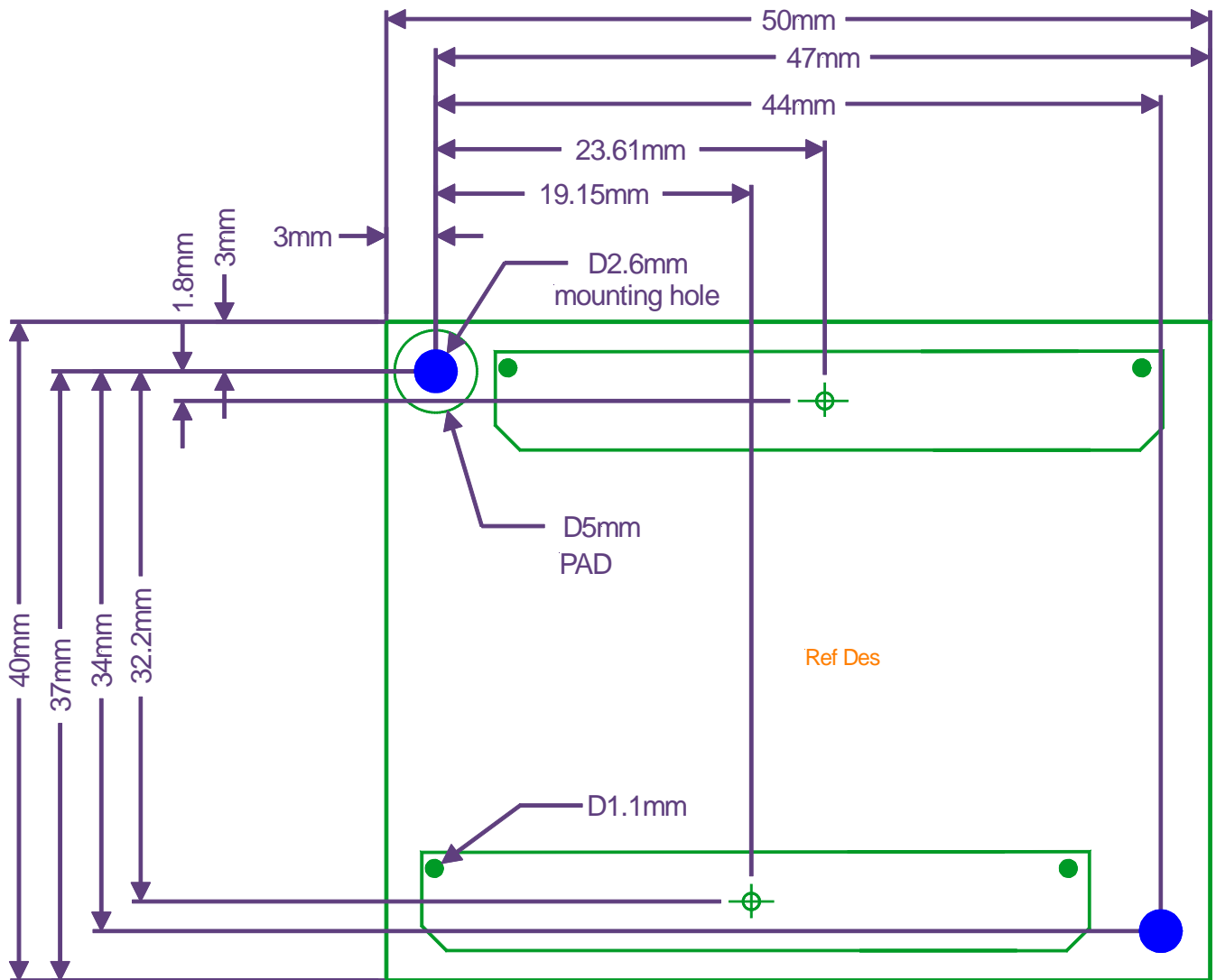

A tolerance of ± 0.1 mm applies to all indicated measures, except for the measures of the outer edges which have a tolerance of ± 0.2 mm

Figure 16: Footprint of the phyCORE-i.MX 6

18.2 Handling the phyCORE-i.MX 6

- **Modifications on the phyCORE Module**

Removal of various components, such as the microcontroller and the standard quartz, is not advisable given the compact nature of the module. Should this nonetheless be necessary, please ensure that the board as well as surrounding components and sockets remain undamaged while de-soldering. Overheating the board can cause the solder pads to loosen, rendering the module inoperable. Carefully heat neighboring connections in pairs. After a few alternations, components can be removed with the solder-iron tip. Alternatively, a hot air gun can be used to heat and loosen the bonds.

Caution!

If any modifications to the module are performed, regardless of their nature, the manufacturer guarantee is voided.

- **Integrating the phyCORE into a Target Application**

Successful integration in user target circuitry greatly depends on the adherence to the layout design rules for the GND connections of the phyCORE module. For maximum EMI performance we recommend as a general design rule to connect all GND pins to a solid ground plane. But at least all GND pins neighboring signals which are being used in the application circuitry should be connected to GND.

19 Revision History

Date	Version numbers	Changes in this manual
04.06.2015	Manual L-808e_1	First edition. Describes the phyCORE-i.MX 6 PCB-Version 1429.1
04.08.2016	Manual L-808e_2	Second edition. Describes the phyCORE-i.MX 6 PCB-Version 1429.2 and 1429.3

Index

1

1000Base-T	36
100Base-T	36
10Base-T	36

A

Audio Interface	40
-----------------------	----

B

Backup Power	25
Block Diagram.....	3
Boot Configuration	27
Boot Device	28
Boot Mode	27
Bootling	27

C

Camera Interfaces.....	49
CAN	41

D

DDR3 RAM	30
DDR3_VREF	23
DDR3-SDRAM	30
Debug Interface	45
Dimensions	57
Display Interface	46

E

EEPROM	30, 31
EEPROM Write Protection.....	32

EMC

eMMC Flash	31
Ethernet	36

F

Features	1
----------------	---

G

General Purpose I/Os.....	43
GND Connection	62

H

Humidity.....	57
---------------	----

I

I ² C EEPROM.....	31
I ² C Interface	40
I ² C Memory.....	21
I ² S	40

J

J1 21	
J3 21	
J4 21, 32	
J6 21	
JTAG Interface	45

L

LAN.....	37
LED	
D144	
LVDS Display Interface.....	47

M

MAC	37
MAC Address	37

N

NAND Flash.....	30, 31
-----------------	--------

O

Operating Temperature	57
Operating Voltage.....	57

P

Parallel Display Interface	46
phyCORE-Connector	7
Physical Dimensions.....	56
Pin Description.....	7
Pinout	
X1-A.....	10
X1-B.....	12
X1-C.....	14
X1-D.....	16
PMIC	22
PMIC_VBAT.....	25
Power Consumption	57
Power Domains	23
Power Management IC	22

Power Supply	6	U12.....	31
R		U14.....	31
RMII Interface.....	38	U16.....	22
RS-232 Level.....	34	U2	36
S		U4-U7	30
SATA Interface	41	U9	32
SD / MMC Card Interfaces.....	33	UART	34
Serial Interfaces	34	USB	
SMT Connector	7	Host Interface	35
SPI Flash.....	30, 32	OTG Interface	35
SPI Interface.....	39	USB Device	35
Storage Temperature	57	USB host.....	35
Supply Voltage	22	USB OTG.....	35
System Configuration	27	User LED	44
System Memory	30	V	
System Power.....	22	VDD_3V3.....	22
T		VDD_DDR3_1V5.....	23
Tamper Detection	55	VDD_eMMC_1V8	23
Technical Specifications.....	56	VDD_MX6_SNVS.....	25
U		Voltage Output.....	25
U11.....	31	W	
		Weight.....	57

Document: phyCORE® -i.MX 6
Document number: L-808e_2, August 2016

How would you improve this manual?

Did you find any mistakes in this manual? _____ **page**

Submitted by:

Customer number: _____

Name: _____

Company: _____

Address: _____

Return to:

PHYTEC Messtechnik GmbH
Postfach 100403
D-55135 Mainz, Germany
Fax : +49 (6131) 9221-33

